

XT Winches

Installation and Maintenance Manual

For Models

XT44AL, XT44CH, XT44R
XT48AL, XT48CH, XT48R
XT52AL, XT52CH, XT52R
XT62AL, XT62CH, XT62R

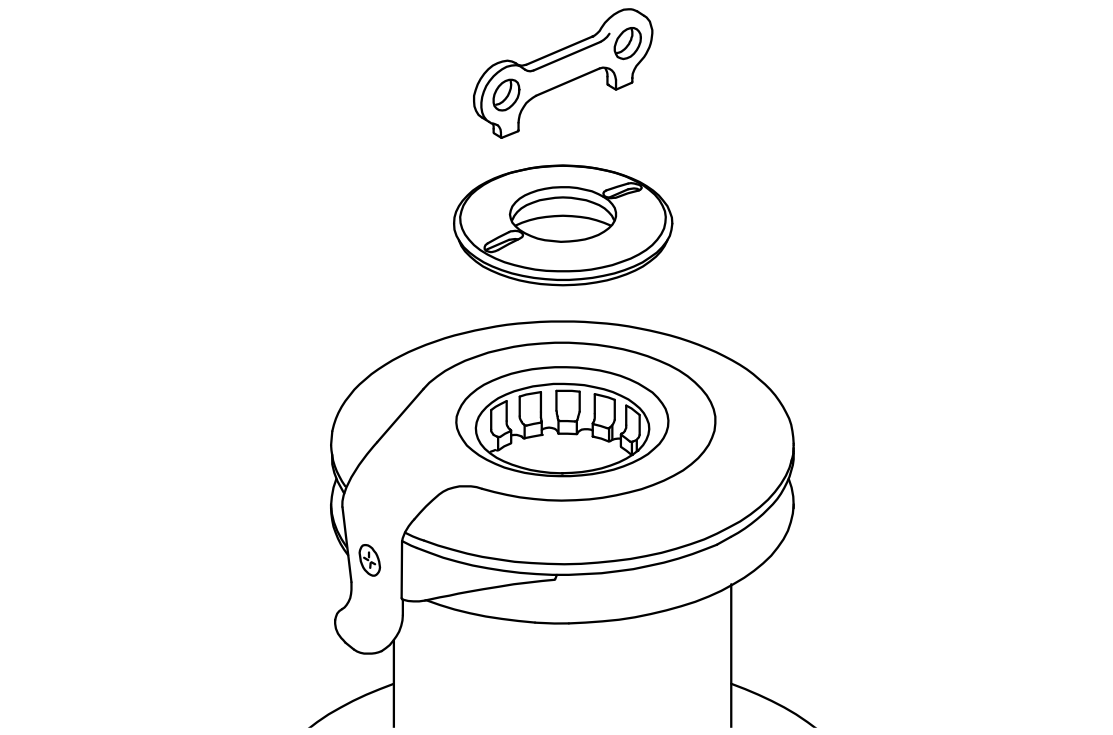

Antal srl unipersonale, Via del Progresso, 10, 35127, Padova, Italy.
Tel. +39 049 8701265. Fax: +39 049 760906. web: www.antal.it

Technical service: antal@antal.it

Installation and Maintenance Manual for Antal XT Winches

Contents

1. About XT Winches	p. 3
2. Use	p. 4
3. Installation	p. 4
4. Maintenance	p. 8
5. Video	p. 11
6. Warranty	p. 12
7. Exploded Views	p. 12

Before You Read This Guide

The present Installation and Maintenance Manual contains important information for the correct use of the XT winch and you are therefore advised to read it carefully before using the product.

The present manual gives technical information for the installation and the maintenance of the following XT winch models: XT44AL, XT44CH, XT44R, XT48AL, XT48CH, XT48R, XT52AL, XT52CH, XT52R, XT62AL, XT62CH, XT62R. In case of technical queries, contact antal@antal.it.

Powered winches. The installation of powered XT winches does not pertain to the purposes of this manual. For the sole maintenance operations, however, it is advised to refer to the indications contained in the section 4 of this manual.

Contacts

Antal srl unipersonale, Via del Progresso, 10, 35127, Padova, Italy.
Tel. +39 049 8701265. Fax: +39 049 760906. web: www.antal.it

Technical service: antal@antal.it

XT44, XT48, XT52, XT62

1. About XT Winches

Important Concepts

Power. Winches are distinguished by power values. The ratio between the force exerted on the handle and the power dispensed by the winch, is said power. For example: if a winch has power 52, it means that when I exert a force 1 on the handle, I get a power of recovery of 52 on the drum (theoretical value that disregards friction).

Recovery speed. To a high power of the winch, there corresponds a reduced recovery speed. On the contrary, to a reduced power, there corresponds a high recovery speed.

Multi-speed. The use of a winch for the recovery of maneuvers requires both speed (in the initial moment) and power (in the final moment). Thus, to maximize the effectiveness of the winch, there are multi-speed winches.

Reduced speed. Recovery speed ratio can be direct or reduced. It is direct when one turn of the handle corresponds to a complete revolution of the drum. On the contrary, the speed is reduced when you need more turns of the handle to complete one revolution of the drum. Thanks to a reduced speed, it does not 'fatigue' and recovery is 'slower'.

The winches **XT44, XT48, XT52, XT62** all have two reduced speeds.

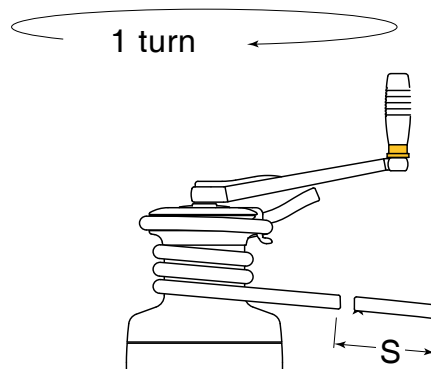

Table of Models

Model	Power		Speed (S) - mm per Turn		Line mm
	1	2	1	2	
XT44	20.0	43.0	80	38	8 - 14
XT48	19.0	47.4	84	34	8 - 14
XT52	15.9	52.8	100	30	8 - 14
XT62	17.8	62.1	89	26	8 - 16

XT44, XT48, XT52, XT62

2. Use

The XT winch is designed for the recovery of a maneuver (halyard, sheet or other line). To use the winch, wind the maneuver with at least four turns around the drum of the winch. After winding to the drum, the maneuver must enter through the ST arm between the two self-regulating disks. In case of slippage of the maneuver, increase the number of turns on the drum.

Diameter of the maneuver in the self-tailing. The lower disk of the self-tailing automatically adapts to the diameter of the maneuver. The movement of the disk is limited to a certain range of diameters for each winch. Lower diameters than those allowed can cause slippage of the maneuver. Conversely, larger diameters may damage the self-tailing. Refer to the table of the models to know the minimum and maximum diameters of maneuvers for each winch.

Use of the winch. All XTs are self-tailing winches and therefore require the sole action of the handle for the recovery of the maneuver. To operate the first power (high speed) insert the handle at the top of the winch, then turn it counterclockwise. To operate the second speed (high power), invert the rotation of the handle and turn clockwise.

3. Installation

Installation is the responsibility of professional personnel. The installer must ensure the good state of the deck where the winch is to be installed. Antal assumes no responsibility for an incorrect installation of the winch.

 **Warning:** an incorrect installation of the winch may cause injuries or damages to things. In case of doubt on how to properly install the winch, contact specialized personnel.

Respect the two following principles for the correct installation of the winch on the deck. Position of the winch on the deck and Placement of the skirt. Only after you have applied these two principles, proceed with installation.

XT44, XT48, XT52, XT62

- ⚠ **Position of the winch on the deck.**
Before installing the winch you must choose a location on the deck that allows the maneuver which you intend to use, to reach the winch at an angle between 2 and 10 degrees.

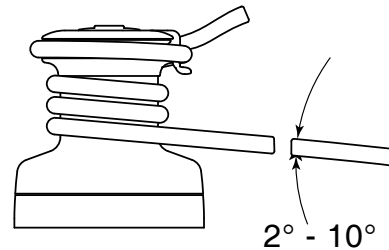

- ⚠ **Placement of the skirt.**
Position the winch so that the output gear is in the area shown in the figure, i.e., tangent to the pull direction of the maneuver.

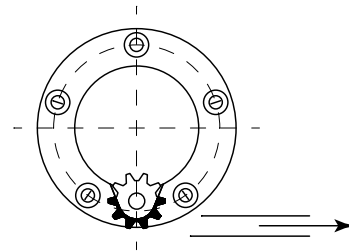
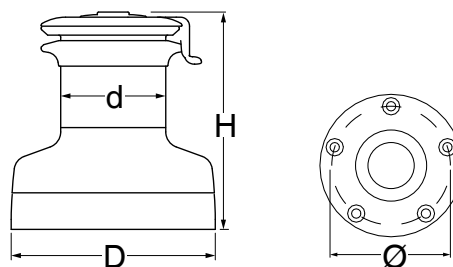

Table of Technical Characteristics



Model	D	d	H	Ø	Screws
	mm			mm	N x mm
XT44	173	93	185	147	6 x 8
XT48	182	93	197	156	6 x 8
XT52	204	105	217	174	6 x 8
XT62	224	120	219	194	6 x 8

XT44, XT48, XT52, XT62

Tools Needed

To install the winch, you will need: supplied key (K) for the opening of the upper ring (R), drill, sealant, screws, bolts and washers.

Screws. Antal does not supply the anchoring screws needed to install the winch. The length of the screws depends on the thickness of the deck. Use screws, washers and bolts in stainless steel AISI 316. Pay attention to the type of screws required UNI5933 - Hexagonal socket countersunk head screws. To learn the screw diameter, see table of technical characteristics above.

Installation Procedure

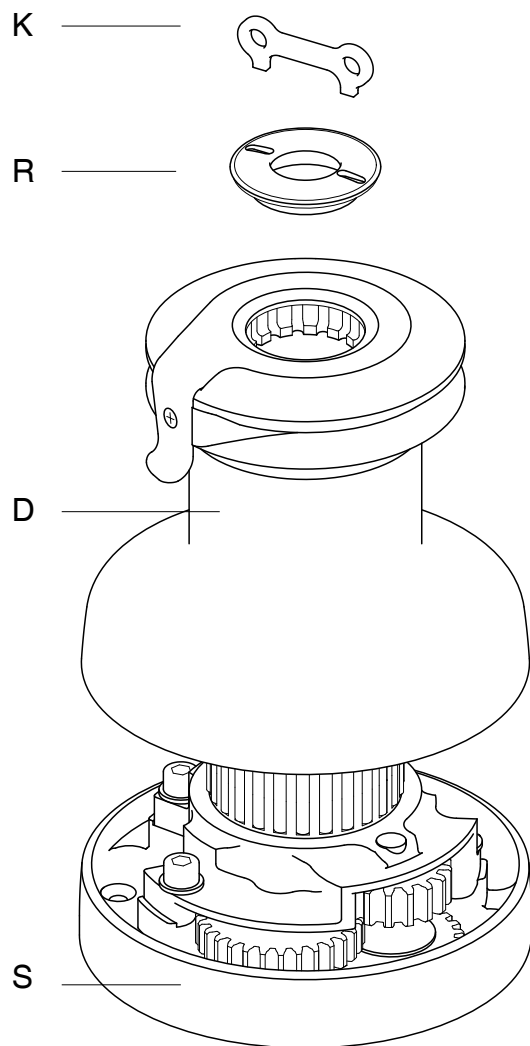

- ① The installation of the XT winch requires that you lift the drum. First of all, unscrew the upper ring (R) with the provided key (K). Thus lift the drum (D) to access the anchoring holes on the skirt (S) of the winch.

XT44, XT48, XT52, XT62

② Fixing the skirt.

Once you have determined the location of the skirt on the deck (see p.5), you can drill the anchoring holes. To determine the position of the holes, mark the deck using the winch's skirt's holes directly. Alternatively, you can download the drilling templates from the internet, at www.antal.it.

Then drill the deck.

In order to prevent water seepage, put sealant around the anchoring holes. Be careful not to obstruct with the sealant the drainage channels at the bottom of the winch.

Thus, tighten the bolts.

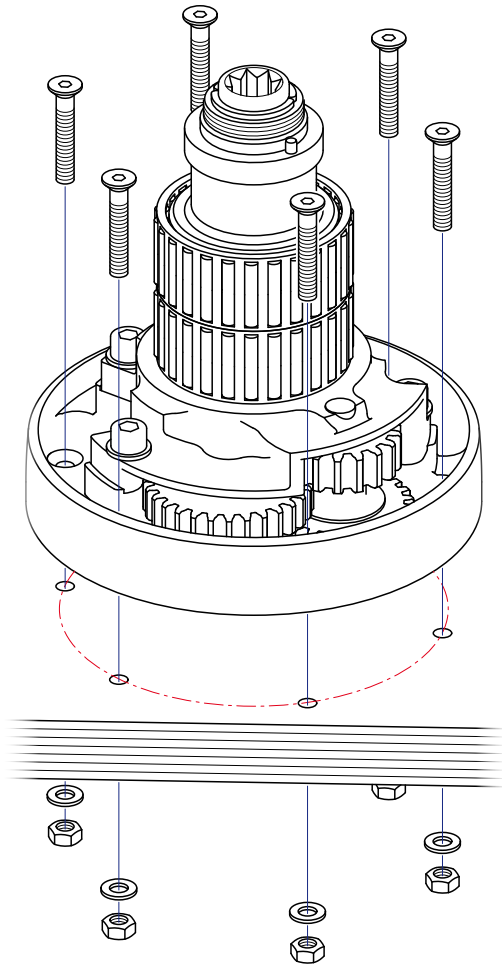

③ Mounting the winch and orientation of the ST arm.

Once you have fixed the winch skirt in the correct position, re-insert the drum.

The XT winches accept a number of possible positions of the drum. Choose the desired rotation of the drum based on the orientation of the ST arm. The orientation of the ST arm depends on where you want to gather the maneuver.

Once the drum is positioned, tighten the upper ring.

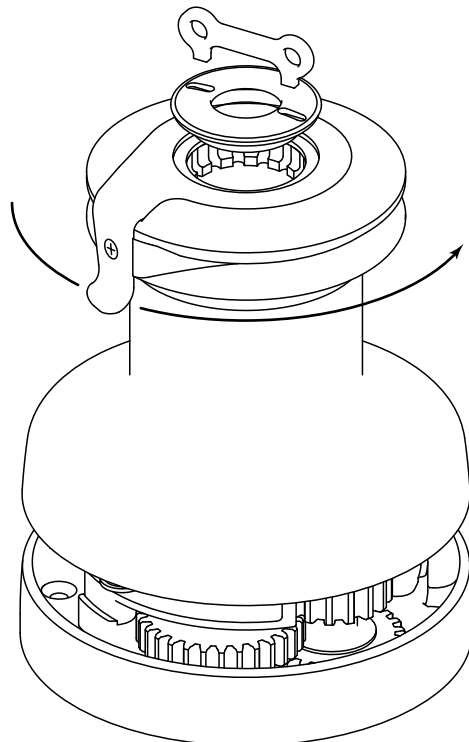

4. Maintenance

Frequent maintenance. All XT winches should be washed frequently, and in any case after each use, to avoid the accumulation of salt. Use plenty of fresh water and clean it on all visible surfaces. Ensure the cleaning of the drainage channels placed at the bottom of the winch, to avoid water stagnation.

Complete maintenance. With seasonal frequency XT winches should be inspected visually inside.

Important Concepts

⚠ **The complete maintenance includes** the opening of the winch, the cleaning of the parts from old lubricants and the new lubrication of all moving parts.

Parts in need of maintenance. The most relevant parts are those subject to movement and rubbing. These are the roller bearings, the gears and pawls, the stem and the inside of the drum. For the complete maintenance of the winch, disassemble the winch in order to access the relevant parts.

TFL 400 Antal Grease. We recommend the use of Antal Grease, a Teflon grease especially made for lubrication of winches and protection of aluminum parts in the marine environment (Mod. TFL400).

Cleaning. Remove old lubricant. In order to do so use a soft bristle brush and solvent (use diesel in case you do not have other solvents).

Lubrication. It increases the performance and prolongs the life of the winch. Also, it prevents the natural accumulation of salt to obstruct the inner mechanism. Also, if you are using the TFL 400 Antal Grease, it also protects the aluminum parts from galvanic corrosion, too.

Thus we advise to put a thin layer of TFL 400 Antal Grease; not only to lubricate all moving parts, but also to protect the aluminum surfaces in contact with s. steel parts, e.g. screws.

Kit Winch. Antal provides a repair kit winch containing pawls and springs (Mod. Kit Winch).

XT44, XT48, XT52, XT62

Maintenance Sequence

- ① **The inner part of the winch.**

Remove the two half rings at the top of the center rod.

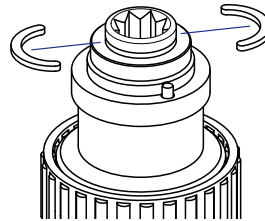

- ② Unscrew the 4 screws on the base and lift the base-stem block.

Cleaning.

Clean the old lubricant from the roller bearings; check the well-being of the stem where the bearings slide; clean the screw-holes on the base, the screws and the washers.

(When re-mounting, it will be necessary to put new grease on all these parts, including the screws' threads. the Antal Grease also serves the function of protection of the aluminum from the risk of galvanic corrosion.)

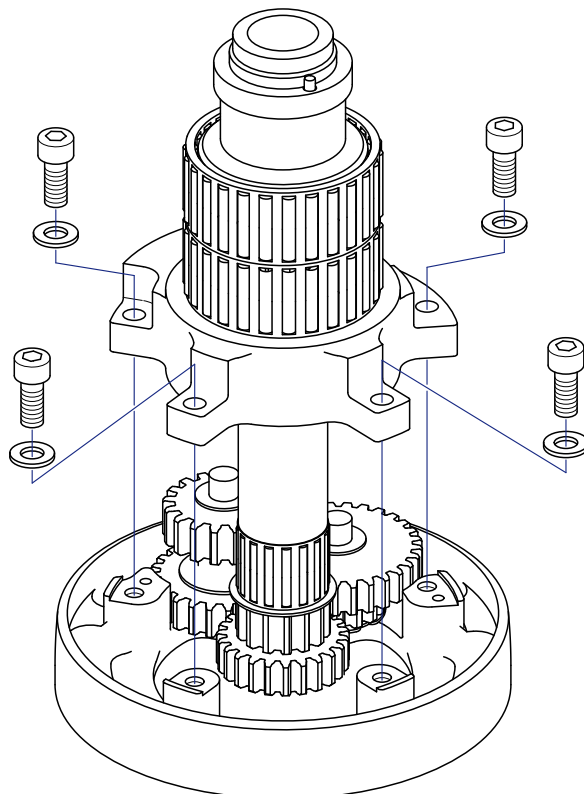

XT44, XT48, XT52, XT62

③ Cleaning.

Now, simply remove the center rod.

Clean the old lubricant from all parts. Lift the roller bearings, the spacers (in case of presence) and the washers. Carefully clean all these parts with a soft bristle brush and solvent.

The cleaning of the gear section and of the gears at the base of the center rod does not require further dismanteling. It will be enough to use a soft bristle brush and solvent.

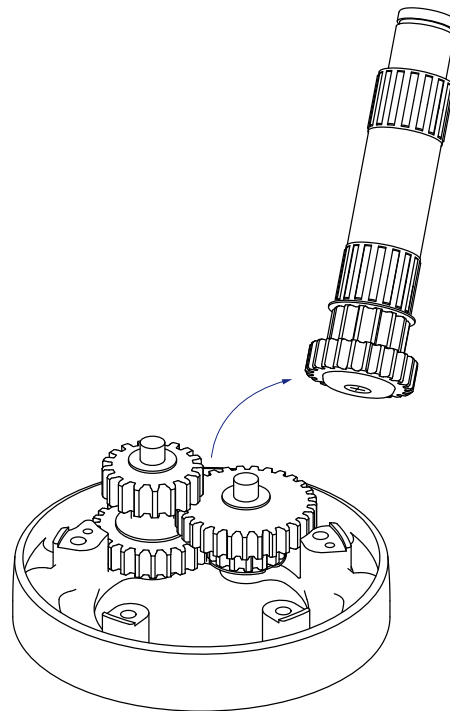

④ Complete inspection.

In case of complete inspection or of the substitution of parts, it is necessary to lift the self-tailing disks to check the good state of the springs, spacers and pawls.

See also exploded view drawings at section 7.

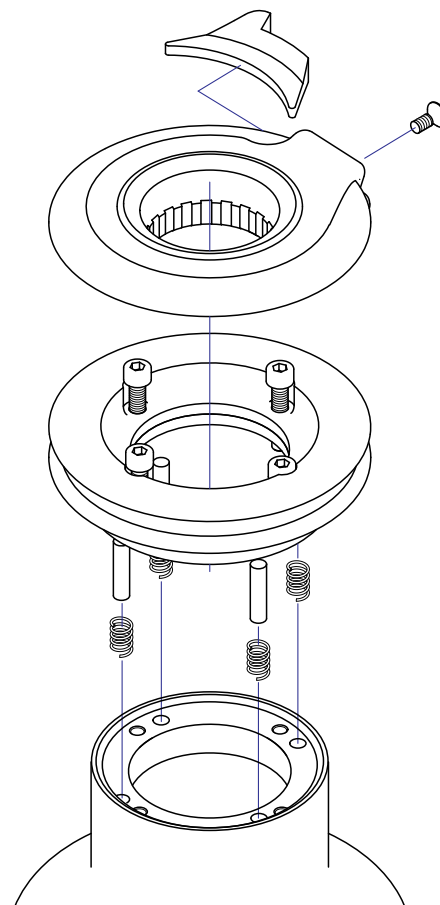

XT44, XT48, XT52, XT62

⑤ Complete inspection.

For the dismantling of the gear section at the bottom of the center rod, proceed by removing parts 34-38 of the exploded view drawing.

Furthermore, open the gear section. The steel axels are isolated from the aluminum parts of the winch thanks to resin insulating gaskets shaped like a hat.

See section 7.

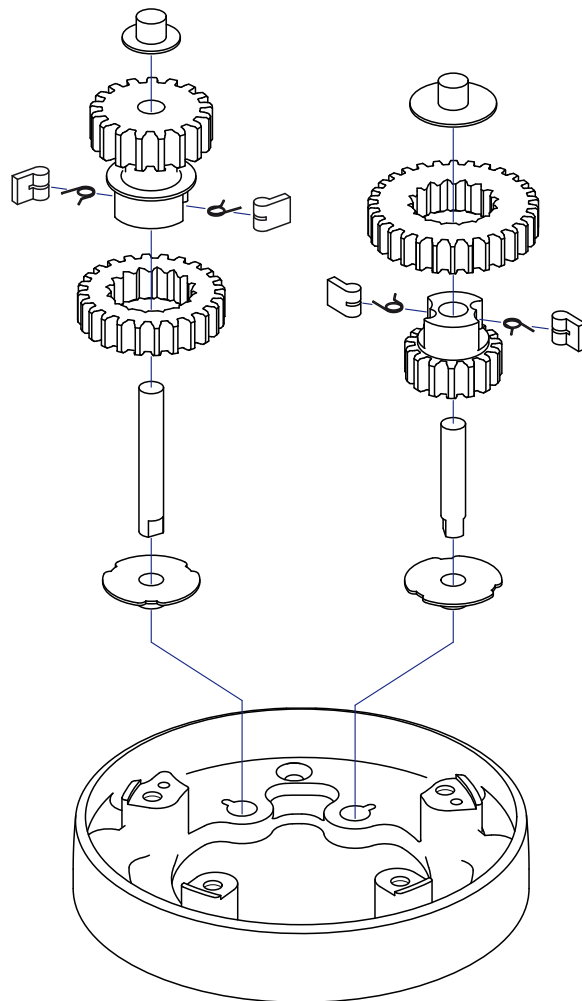

⑥ ⚠ The pawls.

The bronze gears, the pawls and the springs compose a system that transmit motion in a specific way.

While re-mounting the gear section, pay attention to the correct positioning of the outer gear according to the pawls direction.

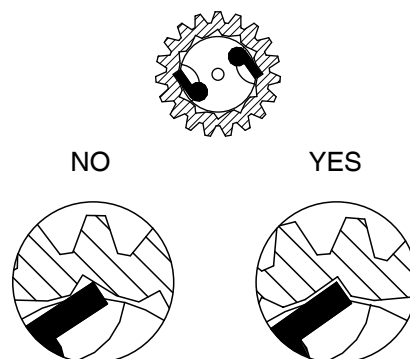

XT44, XT48, XT52, XT62

Spare Parts

Inspect with seasonal frequency the wear status of the internal parts of the winch. In case of damaged parts, order the spare parts from Antal. To identify them, refer to the exploded view drawings at the end of this guide.

Mounting

Reassemble the winch following the steps of the maintenance sequence, in reverse order! In this manual you can also find the exploded view drawings of each model. In case of doubt, contact Antal at techservice@antal.it.

5. Video

Much more information on the Series of Antal XT winches is available in this video.



6. Warranty

Antal guarantees its equipment to be free of defects in material and workmanship for 3 years from the date of purchase. During this period defective parts will be repaired or replaced by Antal. Warranty does not cover: products incorrectly installed; products used in applications for which they are not intended; products used under loads exceeding the product's stated loads; products not properly maintained. Also, warranty does not cover defects due to corrosion, U-V degradation, and normal wear and tear.

Products subject to warranty claim will be returned to Antal for examination and possible repairing or replacement. Antal is not responsible for installation or shipping costs.