

TO BE KEPT WITH BOAT DOCUMENTS  
BEI DEN SCHIFFSPAPIEREN AUFBEWAHREN  
A CONSERVER AVEC LES DOCUMENTS DU BATEAU  
PA ADJUNTAR A LA DOCUMENTACIÓN DE LA EMBARCACION  
BÖR FÖRVARAS I BÅTEN



## Volume 9 Custom Winch Spares Manual

**LEWMAR®**

# CONTENTS

---

<b>CONTENTS</b>	<b>Page</b>
<b>Introduction</b>	
Guarantee Information	3
Service Notes	3
Service Procedures	3
Service & Spares	3
<b>Winches</b>	
No. 77 – 2 Speed Winch	4/5
No. 77 – 3 Speed Winch	6/7
No. 88 – 2 Speed Winch	8/9
No. 88 – 3 Speed Winch	10/11
No. 111 – 2 Speed Winch	12/13
No. 111 – 3 Speed Winch	14/15
No. 122 – 2 Speed Winch & Backwind	16/17
No. 144 – 2 Speed Winch & Backwind	18/19
<b>Owners Service Log</b>	20
<b>Servicing Record</b>	20
<b>Notes</b>	21
<b>Lewmar Limited Warranty</b>	22

# INTRODUCTION

Lewmar is the world's leading manufacturer of yacht winches. Our manufacturing facilities set the highest standards in quality materials and performance. Each Lewmar winch is tested to ensure that all stages in the manufacturing process conform to the Lewmar requirements of dimensional accuracy, rated strength and operating efficiency. Our winches are approved to Lloyds standards and in practice are in excess of them. Lewmar winches are constantly being tested in the latest racing competition, onboard leading ocean racers around the world and, whether racing or cruising, they are rated for their long life and performance.

However, as with any precision engineered assembly, Lewmar winches need regular maintenance to operate at peak efficiency. Without this attention, permanent damage and premature wear can result.

This manual gives complete parts details of custom winches in the Lewmar range together with service, assembly and mounting notes.

Lewmar has a worldwide network of offices and distributors who carry stocks of spare parts and spare kits. Expert advice and assistance is available for any servicing or repair problem.

## Guarantee

Lewmar winches have been developed over many years by extensive testing aboard the world's finest ocean racers, long distance cruising yachts and match racing yachts. They are manufactured to quality standards in excess of those required by Lloyds and only the finest materials are used.

If installed, used and maintained as described in this manual they will give outstanding performance.

## Service Notes

For satisfactory long term performance and product life these winches must be given the routine and full maintenance procedure described below. For detailed information please see service manual "How to Service your Winch" which is available from our offices or through [www.lewmar.com](http://www.lewmar.com).

### Monthly

All Lewmar winches should be hosed down with fresh water then lightly oiled and greased.

### Two or three times during active sailing season

All Lewmar winches should be stripped, cleaned and lubricated.

### At the end of each sailing season or before starting the new season

All Lewmar winches should be completely stripped, cleaned, thoroughly checked for damage, lubricated and reassembled as detailed in this service manual.

## Service Procedures

### Dismantling

Lewmar winches are simple to dismantle and are designed for easy maintenance. The exploded view drawings show how the component parts can be removed easily from each winch.

### Assembly

Winches must be assembled in the reverse sequence to the order of dismantling.

### Mounting

All winches must be mounted using the correct size and type of retaining bolts. The winch must be mounted on a flat clean surface. The hole centres for the winch retaining bolts must be marked off and drilled separately. The winch should be bedded on a light coating of sealing compound to stop leaks – too much compound gets in gears and pawls.

The winch retaining fastenings must be securely tightened (but not overtightened). The winch is self draining and care must be taken to ensure the drain holes are not blocked.

### Handles

All current winches accept any standard international handle.

## Service and Spares

Full service facilities for Lewmar winches are provided at our factory, subsidiary companies, distributors and service centres worldwide. A full listing is provided on our website [www.lewmar.com](http://www.lewmar.com).

Parts pricing is subject to change. Apply to your nearest Lewmar office or distributor for current price lists.

## Recommended Lubricants

Grease – Lewmar grease 7010 (Lubricate Marine Lube 'A', etc.).

Oil – Light Machine Oil (3 in 1 or equivalent).

## Spares Kits

**19700100 Spares Kit 6 – 43** 4 x Standard small pawls and springs, 4 x gear spindle sleeves, 3 x keys, 4 x circlips.

**19700200 Spares Kit 16ST – 66ST** 6 x Standard small pawls, 4 x standard large pawls, 12 x pawl springs, 6 x gear spindle sleeves, 2 x collets, 2 x circlips.

**19700300 Spares Kit 44 – 65PB** (Not applicable for 88 – 144).

**19700401 50 – 66** 6 x Standard large pawls and 12 x pawl springs.

**19700501 6 – 48/66** 6 x Standard small pawls and 12 x pawl springs.

**19700900 Allen key set.**

**19701000 Geargrease™** – Packed in handy 100g plastic tube.

**19701100 Geargrease™** – Packed in handy 300g plastic tub. This waterproof grease contains solid activation which aids the load carrying characteristics of a winch. It is also suitable for trailer wheel bearings, steering gear, hydraulic equipment, onboard engines and many other marine applications.

**19701300 Naval Jelly** – Packed in handy 200ml jar. Removes tarnishing from stainless steel surfaces and protects the material.

**19701600 RaceLube™** – 55ml plastic bottle. High performance winch oil. Special HD22 formula for winch pawls, springs and similar applications, where the use of grease is not advised.

**19701450 English/German/French/Spanish/Swedish – Multi Language 'How to Service your Ocean Winch'.**

Ask your nearest dealer/distributor for a copy of 'How to Service your Ocean Winch' or buy:-

**Winch Maintenance Pack** – 100g tube of grease, 55ml HD22 oil, brush, 'How to' booklet, 10 x pawl springs.

# No.77 - 2 SPEED WINCH

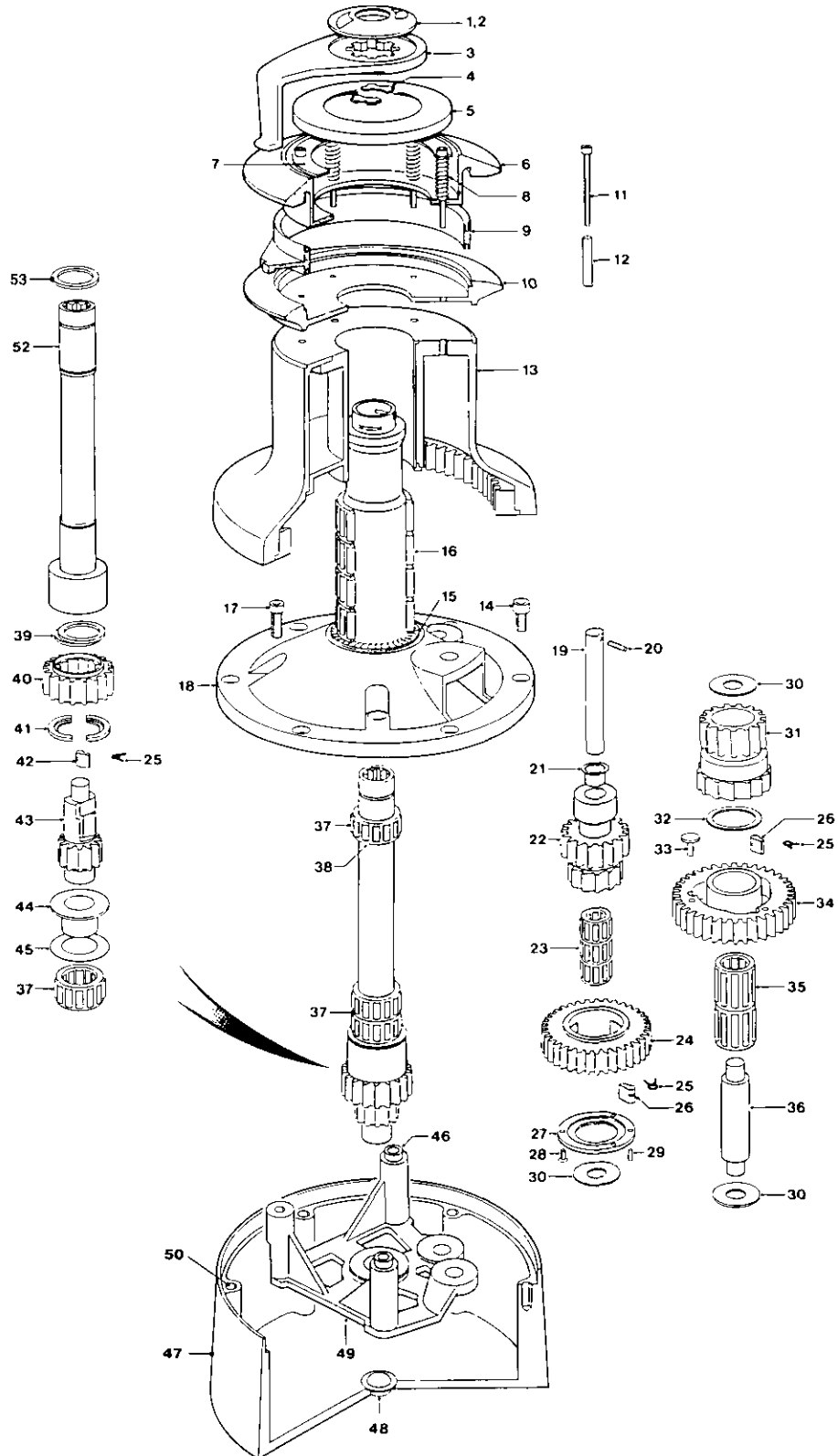

03/06/99

## No.77 - 2 SPEED WINCH

Item	Description	Part No.	No. Off
1	Top Cap	45000700	1
1A	Top Cap (Bronze)	45000701	1
2	'O' Ring	B6061	1
3	Feeder Arm	45002103	1
3A	Feder Arm (Bronze)	45002104	1
4	Collet	45000102	2
5	Spring Cover	45002125	1
6	Upper Crown	45002105	1
6A	Top Cap (All Bronze)	48077000	1
6B	Top Cap (All Chrome)	48077001	1
7	Spring Retainer Plate	45002168	1
8	Spring	45000912	6
9	Stripper Ring	45002108	1
10	Lower Crown	45002109	1
10A	Lower Crown (All Bronze)	48077005	1
10B	Lower Crown (All Chrome)	48077006	1
11	Cap Screw	B0841	6
12	Spacer	45000913	6
13	Drum Assembly	48077010	1
13A	Drum Assembly (Chrome)	48077011	1
13B	Drum Assembly (Bronze)	48077012	1
13C	Drum Assembly (St. Steel)	48077013	1
14	Cap Screw M10 x 20	B0691	6
15	Bearing	18080015	1
16	Bearing	15044121	4
17	Cap Screw M8 x 35	B0760	3
18	Centre Stem	45002017	1
19	Gear Spindle	15000026	1
20	Spirol Pin	B1501	1
21	Washer	45003746	1
22	Idler Gear	45003747	1
23	Bearing	15000017	3

Item	Description	Part No.	No. Off
24	Pawl Gear	45002122	1
25	Pawl Spring	1260/7	8
26	Super Pawl	15000301	6
27	Retainig Plate	15001317	1
28	Posi Screw M5 x 12	B0543	3
29	Dowel	15001188	1
30	Washer	15000247	3
31	Output Gear	45002020	1
32	Washer	15000246	1
33	Retainer Bush	B2233	3
34	Pawl Gear	45002019	1
35	Bearing	15000018	2
36	Gear Spindle	15000035	1
37	Bearing	15000019	4
38	Circlip	B2086	2
39	Spacer	15000022	1
40	Ratchet Gear	15000242	1
41	Split Collet	15000778	2
42	Super Pawl (Small)	15000094	2
43	Spindle Extention	45002182	1
44	Sleeve	15000777	1
45	Washer	15000779	1
46	Hollow Dowl	15065111	2
47	Base	45002130	1
47A	Base (All Chrome)	45002131	1
47B	Base (Bronze)	45002132	1
48	Blanking Plug	B3881	1
49	Bridge Piece	45002063	1
50*	Helicoil	B2424	6
52	2 Speed Main Spindle	45002118	1
53	Washer	15000024	1

\* Not used on bronze or all chrome versions.

### NOTE:

Conversion kit for all bronze and all chrome winch:-

6A + 10A = 48077022

6B + 10B = 48077023

# No.77 - 3 SPEED WINCH

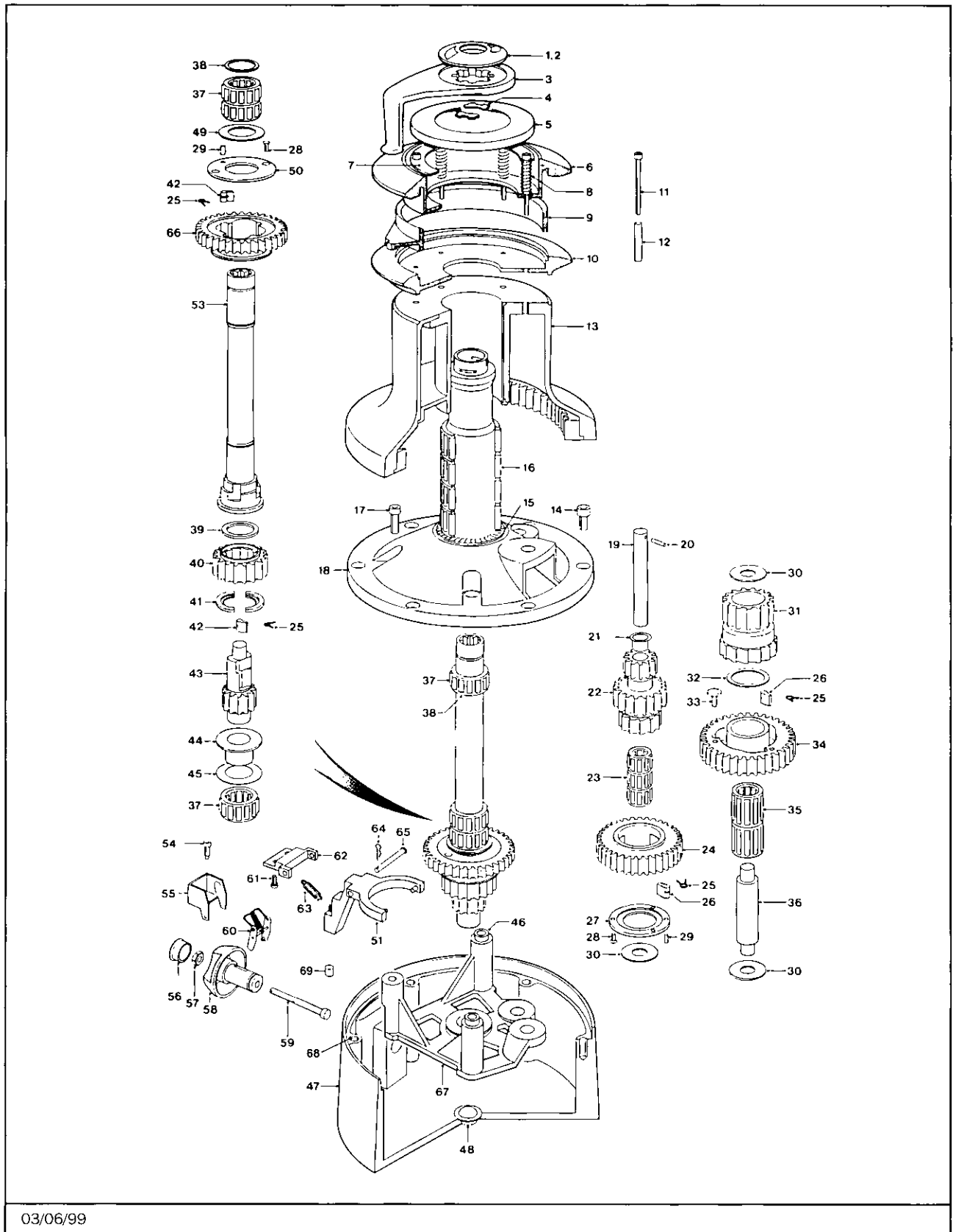

03/06/99

# No.77 - 3 SPEED WINCH

Item	Description	Part No.	No. Off
1	Top Cap	45000700	1
1A	Top Cap (Bronze)	45000701	1
2	'O' Ring	B6061	1
3	Feeder Arm	45002103	1
3A	Feeder Arm (Bronze)	45002104	1
4	Collet	45000102	2
5	Spring Cover	45002125	1
5A	Spring Cover (Black)	45002186	1
6	Upper Crown	45002105	1
6A	Upper Crown (Black)	45002185	1
6B	Upper Crown (All Bronze)	48077000	1
6C	Upper Crown (All Chrome)	48077001	1
7	Spring Retainer Plate	45002168	1
8	Spring	45000912	6
9	Stripper Ring	45002108	1
10	Lower Crown	45002109	1
10A	Lower Crown (Crown) <b>BLACK</b>	45002189	1
10B	Lower Crown (All Bronze)	48077005	1
10C	Lower Crown (All Chrome)	48077006	1
11	Cap Screw	B0841	6
12	Spacer	45000913	6
13	Drum Assembly	48077010	1
13A	Drum Assembly (Black)	48077009	1
13B	Drum Assembly (Chrome)	48077011	1
13C	Drum Assembly (Bronze)	48077012	1
13D	Drum Assembly (St. Steel)	48077013	1
14	Cap Screw M10 x 20	B0691	6
15	Bearing	18080015	1
16	Bearing	15044121	4
17	Cap Screw M8 x 35	B0760	3
18	Centre Stem	45002017	1
19	Gear Spindle	15000026	1
20	Spirol Pin	B1501	1
21	Washer	45003746	1
22	Idler Gear	45003747	1
23	Bearing	15000017	3
24	Pawl Gear	45002122	1
25	Pawl Spring	1260/7	12
26	Super Pawl	15000301	6
27	Retaining Plate	15001317	1
28	Posi Screw M5 x 12	B0543	5
29	Dowel	15001188	1
30	Washer	15000247	3
31	Output Gear	45002020	1

Item	Description	Part No.	No. Off
32	Washer	15000246	1
33	Retainer Bush	B2233	3
34	Pawl Gear	45002019	1
35	Bearing	15000018	2
36	Gear Spindle	15000035	1
37	Bearing	15000019	4
38	Circlip	B2086	2
39	Spacer	15000022	1
40	Ratchet Gear	15000242	1
41	Split Collet	15000778	2
42	Super Pawl (Small)	15000094	6
43	Spindle Extension	45002182	1
44	Sleeve	15000777	1
45	Washer	15000779	1
46	Hollow Dowel	15065111	2
47	Base	45002130	1
47A	Base (Black)	45002142	1
47B	Base (All Chrome)	45002138	1
47C	Base (Bronze)	45002139	1
48	Blanking Plug	B3881	1
49	Washer	15000024	1
50	Retaining Plate	15001318	1
51	Fork	15000041	1
51A	Fork Pin	15000047	2
53	3 Speed Main Spindle	48000002	1
54	Location Screw	15001276	1
55	Push Button Housing	15000203	1
56	Plug	15006010	1
56A	Indicator	B2234	1
57	Nut M6	B1024	1
58	Lock-in Button	45002068	1
59	Plunger	15001313	1
60	Toggle Arm	15000209	1
60A	Toggle Lever	15000204	1
60B	Extension Spring	15000212	1
61	Cap Screw M6 x 12	B0678	2
62	Bracket	15000042	1
63	Fork Spring	15000077	1
64	Fork Spindle Clip	15300158	1
65	Fork Spindle	15000046	1
66	Pawl Gear	45002066	1
67	Bridge Piece	45002063	1
68	M10 Helicoil	B2424	6
69	M6 Helicoil	B2419	1

\* Not used on bronze or all chrome versions.

**NOTE:**

Conversion kit for all bronze and all chrome winch:-

6B + 10B = 48077022

6C + 10C = 48077023

# No.88 - 2 SPEED WINCH

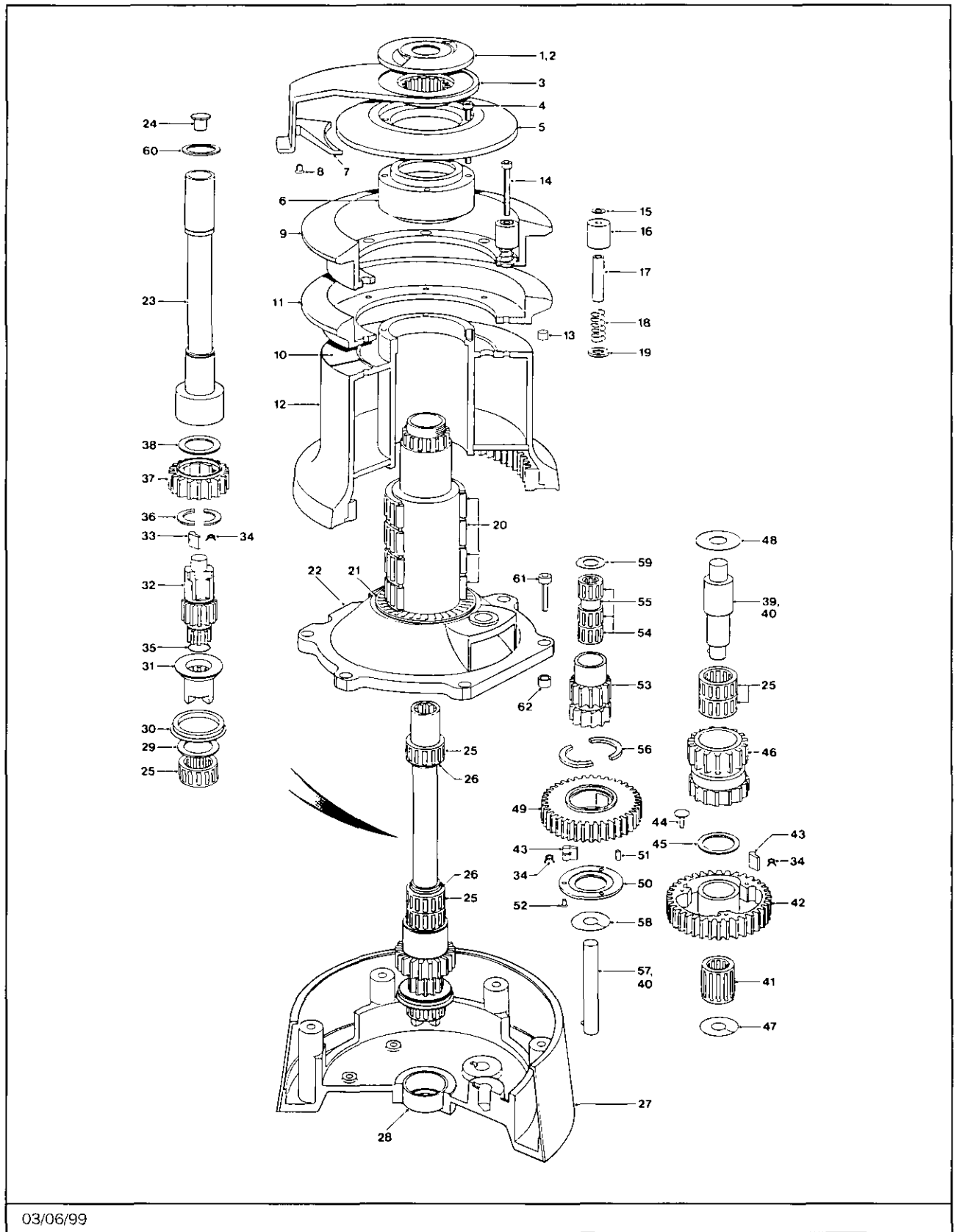

03/06/99



## No.88 – 2 SPEED WINCH

Item	Description	Part No.	No. Off
1	Top Cap (St. Steel)	45002200	1
2	'O' Ring	B7444	1
3	Feeder Arm	48088004	1
4	SKT HD Cap Screw M6 x 50	B0746	4
5	Spring Retainer Cover	45002225	1
6	Drum Spacer	45002274	1
7	Stripper	45002208	1
7A	Insert M5	B1454	2
8	CSK Screw M5 x 12	B0530	2
9	Upper Crown - AL	45002205	1
10	Insulating Shim	45002230	1
11	Lower Crown - AL	45002209	1
12	Drum	48088013	1
13	Buffer	15000723	8
14	SKT HD Cap Screw M6 x 65	B0841	8
15	Washer M6	B1201	8
16	Crown Stop	45002277	8
17	Spacer	45002213	8
18	Compression Spring	B7056	8
19	Spring Washer	45002276	8
20	Bearing	18000020	4
21	Thrust Bearing	18096048	1
22	Centre Stem	45002217	1
23	Main Spindle	45002218	1
24	Spindle Plug	15001942	1
25	Roller Bearing	15000019	6
26	Circlip	B2086	2
27	Winch Base	48088035	1
28	Sleeve	15000053	1
29	Washer	15003669	1
30	V Ring Seal	B2578	1
31	Drive Dog	45002291	1

Item	Description	Part No.	No. Off
32	Spindle Extension	45002282	1
33	Pawl	15000094	2
34	Pawl Spring	1260/7	8
35	'O' Ring	B3736	1
36	Split Collet	15000778	2
37	Ratchet Gear	15000027	1
38	Spacer	15000022	1
39	Gear Spindle	15003038	1
40	Spirol Pin	B1501	2
41	Roller Bearing	15000018	1
42	Pawl Gear	15003830	1
43	Pawl	15000301	6
44	Retainer	B2233	3
45	Washer	15003075	1
46	Ratchet Gear	15003586	1
47	Washer	15003074	1
48	Washer	15003076	1
49	Pawl Gear	15003590	1
50	Retaining Plate	15001317	1
51	Dowel	15001188	1
52	POZ CSK Screw M5 x 12	B0543	3
53	Ratchet Gear	15003841	1
54	Roller Bearing	15000017	3
55	Bearing Spacer	15003596	1
56	Collet	15003595	2
57	Gear Spindle (Idler)	15003037	1
58	Washer	15000247	1
59	Washer	15003598	1
60	Washer	15000024	1
61	SKT HD Cap Screw M10 x 25	B0692	6
62	Hollow Dowel	15001092	3

# No.88 - 3 SPEED WINCH

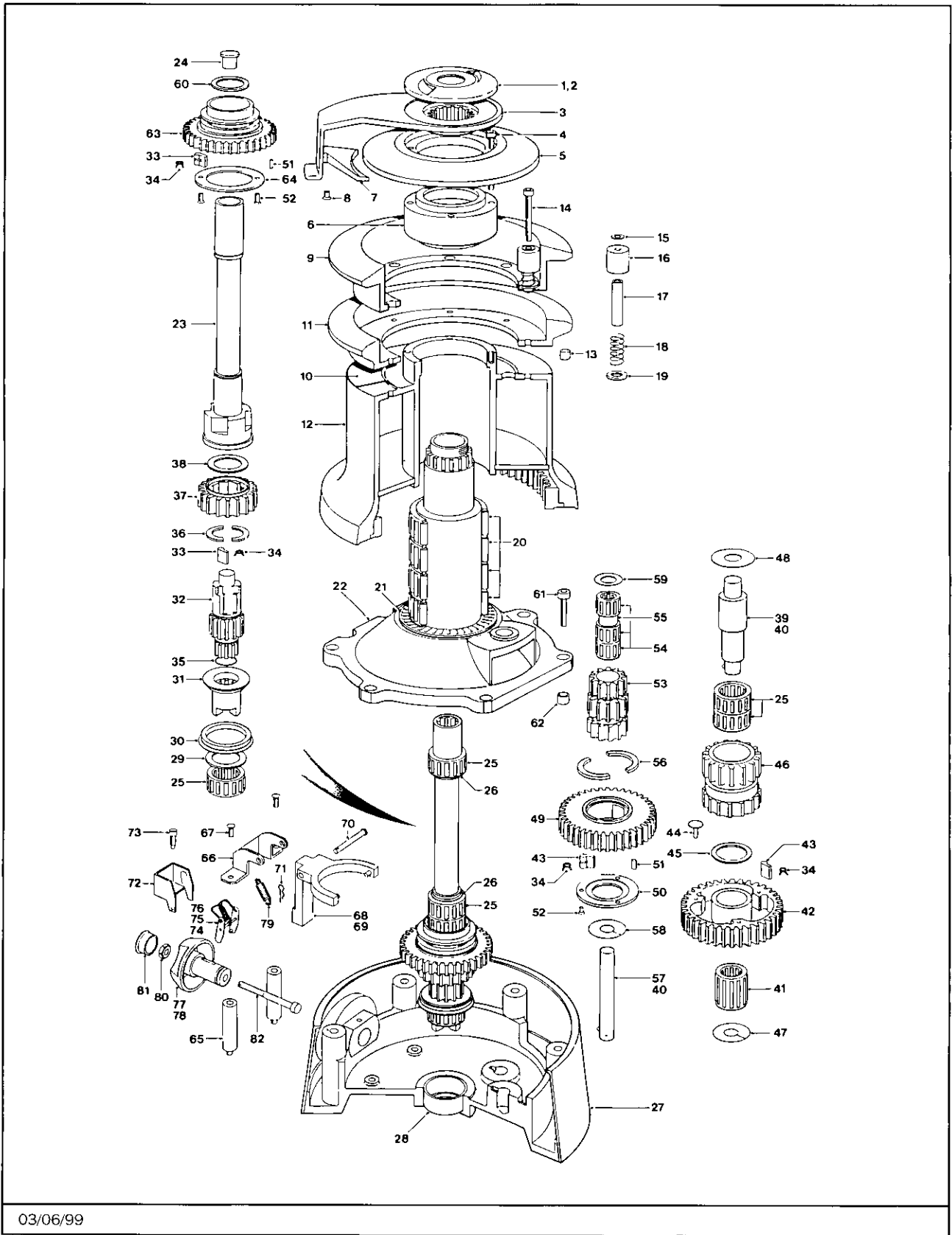

03/06/99

## No.88 – 3 SPEED WINCH

Item	Description	Part No.	No. Off
1	Top Cap (St.Steel)	45002200	1
2	'O' Ring	B7444	1
3	Feeder Arm	48088004	1
4	SKT HD Cap Screw M6 x 50	B0746	4
5	Spring Retainer Cover	45002225	1
6	Drum Spacer	45002274	1
7	Stripper	45002208	1
7A	Brass Insert	B1454	2
8	CSK Screw M5 x 12	B0530	2
9	Upper Crown - AL	45002205	1
10	Insulating Shim	45002230	1
11	Lower Crown - AL	45002209	1
12	Drum	48088013	1
13	Buffer	15000723	8
14	SKT HD Cap Screw M6 x 65	B0841	8
15	Washer M6	B1201	8
16	Crown Stop	45002277	8
17	Spacer	45002213	8
18	Compression Spring	B7056	8
19	Spring Washer	45002276	8
20	Bearing	18000020	4
21	Thrust Bearing	18096048	1
22	Centre Stem	45002217	1
23	Main Spindle	48000004	1
24	Spindle Plug	15001942	1
25	Roller Bearing	15000019	6
26	Circlip	B2086	2
27	Winch Base	48088034	1
28	Sleeve	15000053	1
29	Washer	15003669	1
30	V Ring Seal	B2578	1
31	Drive Dog	45002291	1
32	Spindle Extension	45002282	1
33	Pawl	15000094	6
34	Pawl Spring	1260/7	12
35	'O' Ring	B3736	1
36	Split Collet	15000778	2
37	Ratchet Gear	15000027	1
38	Spacer	15000022	1
39	Gear Spindle	15003038	1
40	Spirol Pin	B1501	2
41	Roller Bearing	15000018	1

Item	Description	Part No.	No. Off
42	Pawl Gear	15003830	1
43	Pawl	15000301	6
44	Retainer	B2233	3
45	Washer	15003075	1
46	Ratchet Gear	15003586	1
47	Washer	15003074	1
48	Washer	15003076	1
49	Pawl Gear	15003590	1
50	Retaining Plate	15001317	1
51	Dowel	15001188	2
52	POZ CSK Screw M5 x 12	B0543	5
53	Ratchet Gear	15003588	1
54	Roller Bearing	15000017	3
55	Bearing Spacer	15003596	1
56	Collet	15003595	2
57	Gear Spindle (Idler)	15003037	1
58	Washer	15000247	1
59	Washer	15003598	1
60	Washer	15000024	1
61	SKT HD Cap Screw M10 x 25	B0692	6
62	Hollow Dowel	15001092	3
63	Pawl Gear	15003819	1
64	Retaining Plate	15003122	1
65	Bracket Pillar	45002290	2
66	Fork Bracket	15003124	1
67	SKT HD Cap Screw M6 x 16	B0679	2
68	Fork	15003109	1
69	Fork Pin	15000047	2
70	Spindle Fork	15000046	1
71	Clip	15300158	1
72	Push Button Housing	15000203	1
73	Locating Screw	15001276	1
74	Toggle Lever	15000204	1
75	Toggle Arm	15000209	1
76	Spring	15000212	1
77	Push Button	45002068	1
78	Push Button Indicator	B2234	1
79	Fork Spring	15000077	1
80	STD HX Nut M6	B1024	1
81	Plug	15006010	1
82	Plunger	45002292	1

# No.111 – 2 SPEED WINCH

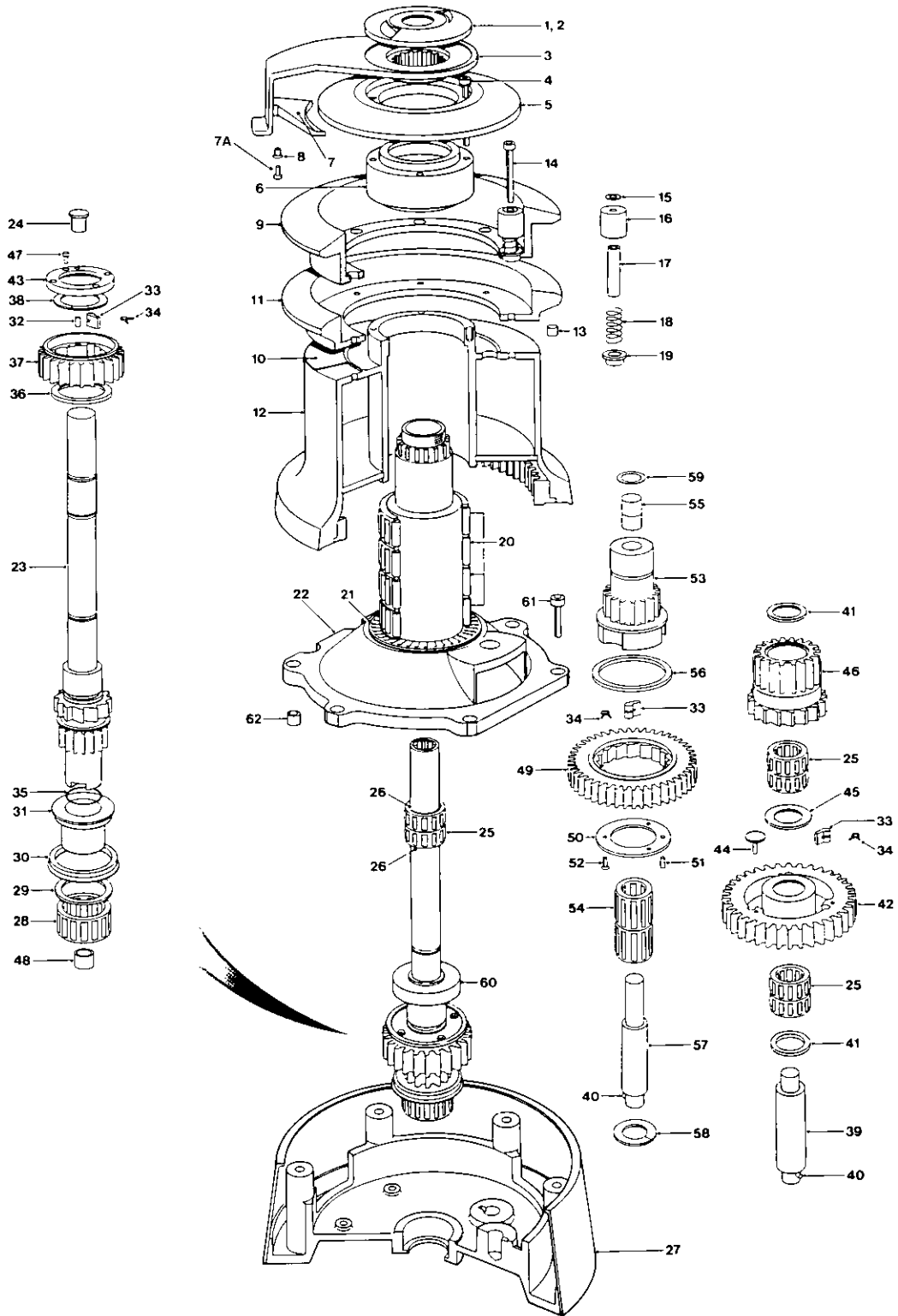

03/06/99

## No.111 – 2 SPEED WINCH

Item	Description	Part No.	No. Off
1	Top Cap	45002200	1
2	'O' Ring	B7444	1
3	Feeder Arm	48111004	1
4	SKT HD Cap Screw M6 x 70	B0751	4
5	Spring Retainer Cover	45002425	1
6	Drum Spacer	45002474	1
7	Stripper Tongue	45002408	1
7A	Insert M5	B1454	2
8	CSK Screw M5 x 16	B0558	2
9	Upper Crown - AL	45002405	1
10	Insulating Shim	45002430	1
11	Lower Crown - AL	45002409	1
12	Drum Assembly	48111014	1
13	Buffer	15000723	8
14	SKT HD Cap Screw M8 x 70	B0761	8
15	Washer M8	B1206	8
16	Crown Stop	45002477	8
17	Spacer	45002413	8
18	Compression Spring	B1776	8
19	Crown Bush	45002484	8
20	Bearing	18000020	4
21	Thrust Bearing	18096048	1
22	Centre Stem	45002417	1
23	Main Spindle	45002480	1
24	Spindle Plug	15001942	1
25	Roller Bearing	15000019	8
26	Circlip	B2086	3
27	Winch Base	48111035	1
28	Roller Bearing	15008007	1
29	Washer	15000720	1
30	V Ring Seal	B2597	1
31	Spindle Sleeve	45002488	1

Item	Description	Part No.	No. Off
32	Dowel 6 x 15	15300680	1
33	Pawl	15000301	13
34	Pawl Spring	15000722	13
35	'O' Ring	B6067	1
36	Support Plate	45002494	1
37	Pawl Gear	45002498	1
38	Collet	15000713	2
39	Gear Spindle	45002423	1
40	Spirol Pin	B1501	2
41	Washer	45002426	2
42	Pawl Gear	45002419	1
43	Retaining Plate	45002496	1
44	Retainer	B2233	3
45	Washer	15000024	1
46	Ratchet Gear	45002420	1
47	SKT HD Cap Screw	B0758	4
48	Spindle Bush	45002487	1
49	Ratchet Gear	45002421	1
50	Retaining Plate	15001451	1
51	Dowel	15300293	1
52	POZ CSK Screw M5 x 12	B0543	3
53	Pawl Gear	45002416	1
54	Roller Bearing	15000018	2
55	Bearing	B5225	2
56	Bearing Washer	15000718	1
57	Gear Spindle	45002424	1
58	Washer	15000719	1
59	Washer	15000765	1
60	Spindle Thrust Washer	45002482	1
61	SKT HD Cap Screw M10 x 25	B0692	8
62	Hollow Dowel	15001092	4

# No.111 - 3 SPEED WINCH

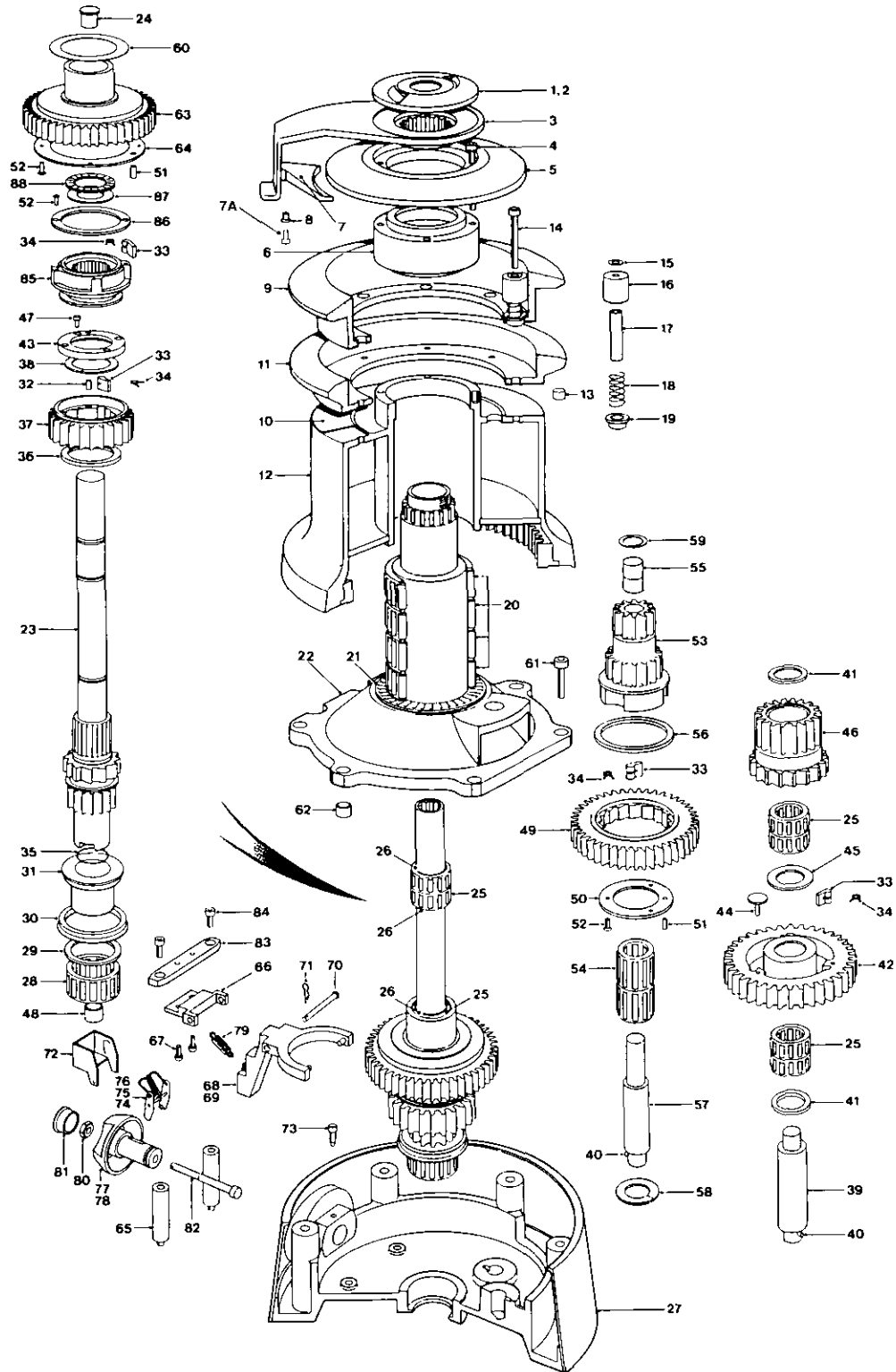

03/06/99

# No.111 – 3 SPEED WINCH

Item	Description	Part No.	No. Off
1	Top Cap	45002200	1
2	'O' Ring	B7444	1
3	Feeder Arm	48111004	1
4	SKT HD Cap Screw M6 x 70	B0751	4
5	Spring Retainer Cover	45002425	1
6	Drum Spacer	45002474	1
7	Stripper Tongue	45002408	1
7A	Insert M5	B1454	2
8	CSK Screw M5 x 16	B0558	2
9	Upper Crown - AL	45002405	1
10	Insulating Shim	45002430	1
11	Lower Crown - AL	45002409	1
12	Drum Assembly	48111014	1
13	Buffer	15000723	8
14	SKT HD Cap Screw M8 x 70	B0761	8
15	Washer M8	B1206	8
16	Crown Stop	45002477	8
17	Spacer	45002413	8
18	Compression Spring	B1776	8
19	Crown Bush	45002484	8
20	Bearing	18000020	4
21	Thrust Bearing	18096048	1
22	Centre Stem	45002417	1
23	Main Spindle	45002418	1
24	Spindle Plug	15001942	1
25	Roller Bearing	15000019	8
26	Circlip	B2086	3
27	Winch Base	48111034	1
28	Roller Bearing	15008007	1
29	Washer	15000720	1
30	V Ring Seal	B2597	1
31	Spindle Sleeve	45002488	1
32	Dowel 6 x 15	15300680	1
33	Pawl	15000301	13
34	Pawl Spring	15000722	13
35	'O' Ring	B6067	1
36	Support Plate	45002494	1
37	Pawl Gear	45002498	1
38	Collet	15000713	2
39	Gear Spindle	45002423	1
40	Spirol Pin	B1501	2
41	Washer	45002426	2
42	Pawl Gear	45002419	1
43	Retaining Plate	45002496	1
44	Retainer	B2233	3

Item	Description	Part No.	No. Off
45	Washer	15000024	1
46	Ratchet Gear	45002420	1
47	SKT HD Cap Screw M5 x 12	B0758	4
48	Spindle Bush	45002487	1
49	Ratchet Gear	45002421	1
50	Retaining Plate	15001451	1
51	Dowel	15300293	1
52	POZ CSK Screw M5 x 12	B0543	9
53	Pawl Gear	45002416	1
54	Roller Bearing	15000018	2
55	Bearing	B5225	2
56	Bearing Washer	15000718	1
57	Gear Spindle	45002424	1
58	Washer	15000719	1
59	Washer	15000765	1
60	Washer	45002427	1
61	SKT HD Cap Screw M10 x 25	B0692	8
62	Hollow Dowel	15001092	4
63	Pawl Gear	45002466	1
64	End Plate	15001447	1
65	Bracket Pillar	45002490	2
66	Bracket	15000042	1
67	SKT HD Cap Screw M6 x 12	B0678	2
68	Fork	15000711	1
69	Fork Pins	15000047	2
70	Fork Spindle	15000046	1
71	Clip	15300158	1
72	Push Button Housing	15000203	1
73	Locating Screw	15001276	1
74	Toggle Lever	15000204	1
75	Toggle Arm	15000209	1
76	Spring	15000212	1
77	Push Button	45002068	1
78	Push Button Indicator	B2234	1
79	Fork Spring	15000077	1
80	STD HX Nut No.6	B1024	1
81	Plug	15006010	1
82	Plunger	15001441	1
83	Bridge Plate	15001440	1
84	SKT HD Cap Screw M8 x 16	B0759	2
85	Pawl Carrier	15001442	1
86	Retainer Plate	15001450	1
87	Washer	15300109	1
88	Thrust Bearing	18000007	1

# No.122 – 2 SPEED WINCH & BACKWIND

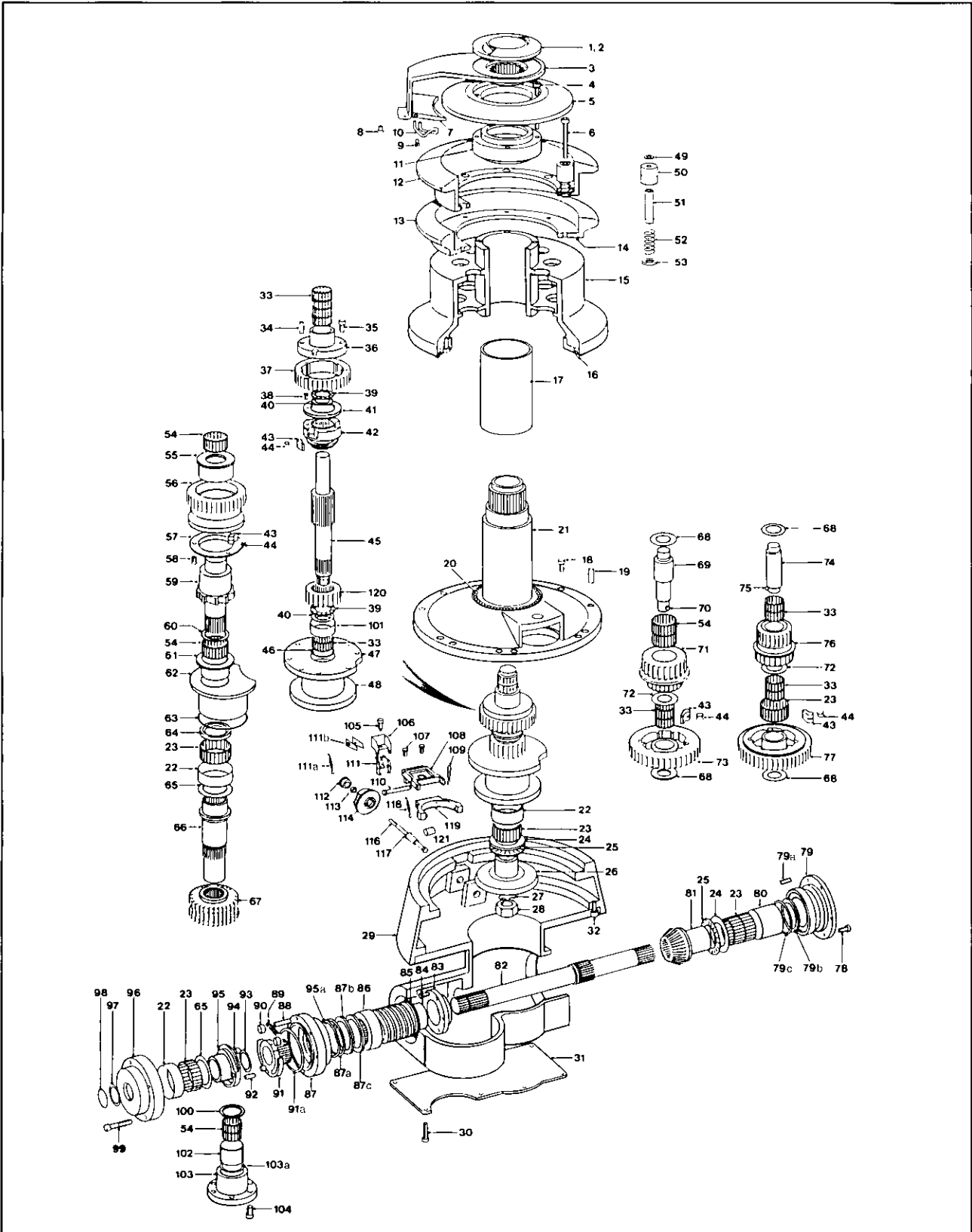

03/06/99



# No.122 – 2 SPEED WINCH & BACKWIND

Item	Description	Part No.	No. Off
1	Top Cap	45002500	1
2	O' Ring	B7D41	1
3	Feeder Arm	48111004	1
4	SKT HD Cap Screw M6 x 60	B0750	4
5	Spring Retainer Cover	45002525	1
6	SKT HD Cap Screw M10 x 80	B0745	8
7	Stopper Ring	45002508	1
7A	Brass Insert M6	B1455	2
7B	Brass Insert M5	B1456	1
8	CSK Screw M5 x 16	B0558	2
9	Hook Retainer	45002565	1
10	Hook	45002564	1
11	Spacer	45002574	1
12	Upper Crown	45002505	1
13	Lower Crown	45002509	1
13A	Buffer	15000723	6
14	Gasket	45002530	1
15	Drum Assembly	48120014	1
16	Lip Seal	B8328	1
17	Bearing	45002533	1
18	Screw M12 x 25	B0828	9
19	Dowel	15000619	1
20	Helin Ball	B4721	67
21	Centre Stem	45002517	1
21A	Sleeve	15000617	1
22	Maxi Sleeve	15000569	3
23	Bearing	15010007	6
24	Maxi Washer	15000580	2
25	Bearing	18080015	2
26	Bevel Gear Maxi	15000579	1
27	Lock Washer	B1225	1
28	Lock Nut	B1025	1
29	Base Sub Assembly	48002537	1
29A	D Helicoh M6 x 1.5	B2419	17
29B	D Helicoh M10 x 1.5	B2424	16
29C	D Helicoh M8 x 1.5	B2423	20
30	SKT HD Cap Screw M6 x 12	B0678	8
31	Cover Plate	15000618	1
32	SKT HD Cap Screw M10 x 30	B0693	9
33	Bearing	15000019	12
34	Dowel	15300293	1
35	SKT HD Cap Screw M6 x 16	B0679	3
36	Gear Support	15001504	1
37	Ratchet Gear	15001502	1
38	Posi Screw M5 x 12	B0530	3
39	Bearing	18000007	3
40	Washer	15300109	3
41	Retainer Plate	15001506	1
42	Pawl Carrier	15001503	1
43	Pawl	15000577	24
44	Pawl Spring	124977	24
45	Maxi Spindle	15000587	1
46	Seal	B2581	1
47	O' Ring	B2533	1
48	Centre Bearing Hub Maxi	15000588	1
48A	Hollow Dowel	15065111	2
48B	Dowty Seal	B2581	1
48C	SKT HD Cap Screw M8 x 25	B0687	12
48D	SKT HD Cap Screw M8 x 30	B0688	2
48E	Maxi Shim	15000554	2
48F	0.5mm Shim	15003366	1
48G	1mm Shim	15003367	1
49	Washer	B1223	8
50	Crown Stop	45002577	8
51	Spacer	45002513	8
52	Spring	B7057	8
53	Washer	45002576	8
54	Bearing	15008007	6
55	Sleeve	15000607	1
56	Backwind Gear	15001501	1
57	Retainer	15000608	1
58	Posi Screw M6 x 12	B0533	3
59	Backwind Spindle	15000606	1
60	Washer	15000611	1
61	Flanged Sleeve	15000609	1
62	Bearing Housing	15001499	1

Item	Description	Part No.	No. Off
63	O' Ring	B2534	1
64	Lip Seal	B2588	1
65	Washer	15000568	2
66	Maxi Spindle	15000583	1
67	Maxi Worm Wheel	15000576	1
68	Washer	15000599	4
69	Gear Spindle	15000598	1
70	Dowel	B1501	1
71	Ratchet Gear	15000590	1
72	Washer	15000600	2
73	Pawl Gear	15000589	1
74	Fear Spindle	15000597	1
75	Dowel	B1501	1
76	Ratchet Gear	15000593	1
77	Pawl Gear	15000592	1
78	SKT HD Cap Screw M10 x 55	B0766	8
79	End Cap	40001560	1
79A	Dowel	15000621	1
79B	O' Ring	B7032	1
79C	Quad Ring	B6256	1
80	Sleeve	15000582	1
81	Maxi Bevel Gear	15000578	1
82	Drive Shaft	40001564	1
83	Housing	45002583	1
83A	Dowel	15300293	3
84	CSK Screw M6 x 20	B0552	6
85	Friction Disc	40001565	1
86	Maxi Worm	40001563	1
87	Lock Body Housing	40001561	1
87A	O' Ring	B7032	1
87B	Quad Ring	B6257	1
87C	Thrust Washer	40001872	1
88	Dowel	40001566	1
89	Spring	B1775	1
90	Roller	15000571	2
91	Lock Body	40001562	1
91A	O' Ring	B7501	1
92	Spring Retainer	15000572	1
93	Washer	15000566	1
94	Drive Pin	15000563	1
94A	Maxi Shim	15000556	4
94B	Pin	15080570	2
95	Drive Body	40001875	1
95A	Thrust Washer	40001873	1
96	Bearing Housing	45002548	1
96A	Maxi Shim	45002589	1
96B	0.5mm Shim	15003368	1
96C	1mm Shim	15003369	1
97	Made to Suit		
98	Circlip	B2001	2
99	SKT HD Cap Screw M10 x 90	B0840	8
100	Washer	15000605	1
101	Bearing Sleeve	15000053	1
102	Sleeve	15000604	1
103	Bearing Housing	15001500	1
103A	O' Ring	B8303	1
104	SKT HD Cap Screw	B0686	6
105	Location Screw	15001276	1
106	Push Button Housing	15000203	1
107	SKT HD Cap Screw M6 x 12	B0678	2
108	Bracket	15000615	1
109	Clip	15300138	1
110	Fork Spindle	15000046	1
111	Toggle Arm	15000209	1
111A	Toggle Lever	15000204	1
111B	Spring	15000212	1
112	Plug	15000610	1
113	Nut M6	B1024	1
114	Push Button	45002067	1
114A	Indicator	B2234	1
116	Plunger	45002592	1
117	Sleeve	15000378	1
118	Fork Spring	15000077	1
119	Fork	15000555	1
120	Spindel Gear	15000591	1
121	Fork Pin	15000622	2

# No.144 – 2 SPEED WINCH & BACKWIND

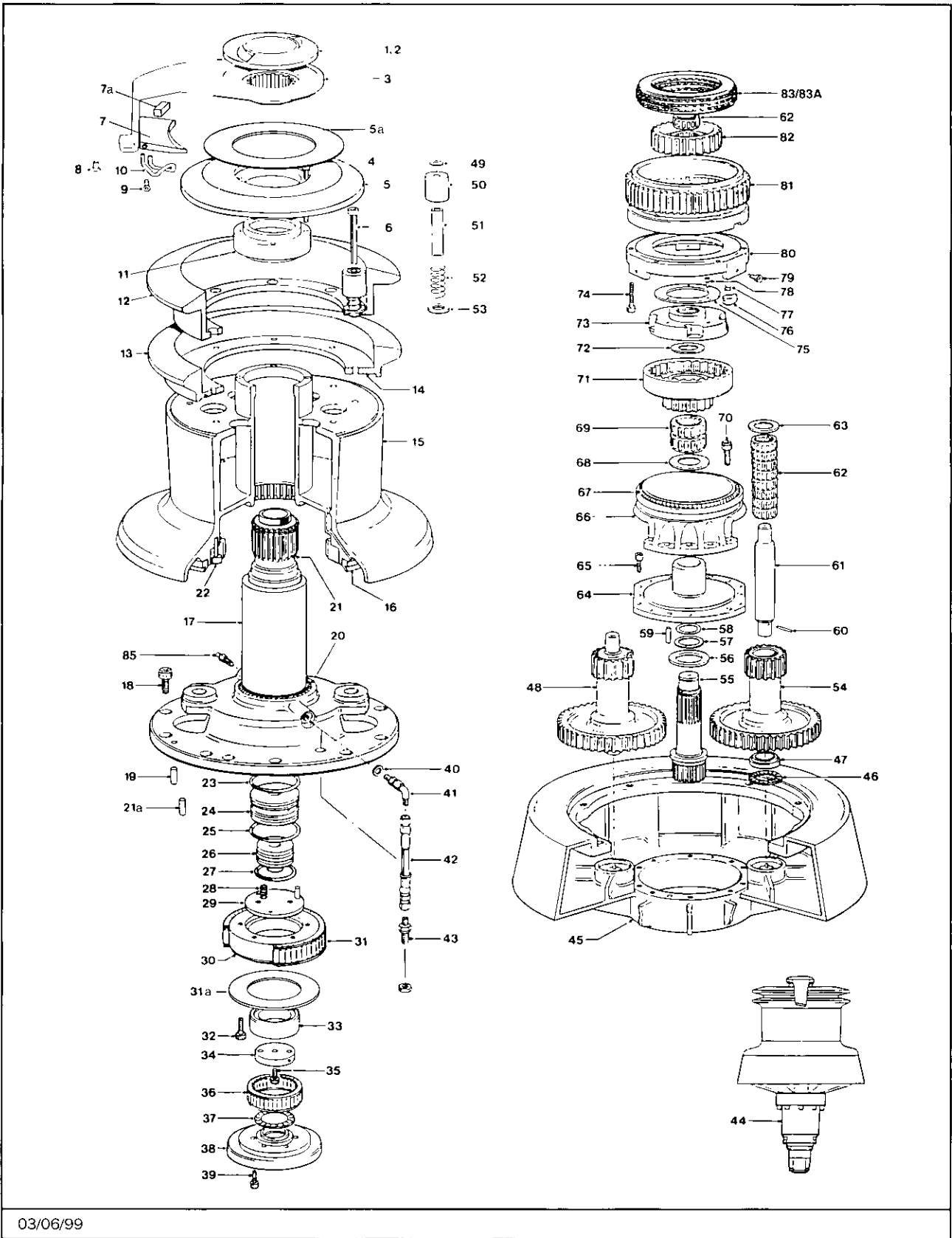

03/06/99

## No.144 – 2 SPEED WINCH & BACKWIND

Item	Description	Part No.	No. Off
1	Top Cap	45002500	1
2	'O' Ring	B7041	1
3	Feeder Arm	48144004	1
4	SKT HD Cap Screw M6 x 60	B0750	4
5	Spring Retainer Cover	45002625	1
5A	Name Plate	45002628	1
6	SKT HD Cap Screw M10 x 80	45002474	8
7	Stripper	45002608	1
7A	Stripper Clamp Plate	45002607	1
8	CSK Screw M4 x 12	B0409	2
9	Hook Retainer	45002565	1
10	Hook	45002564	1
11	Spacer	45002674	1
12	Upper Crown	48144003	1
13	Lower Crown	45002609	1
14	Gasket	45002630	1
15	Drum Assembly	48144014	1
16	Lip Seal	B2799	1
17	Bearing	40002633	1
18	Cap Screw M12 x 25	B0828	10
19	Dowel	15000619	1
20	Delrin Ball	B1726	90
21	Centre Stem	45002617	1
21A	Dowel	15001188	3
22	Drum Assembly	48144014	1
23	'O' Ring	B6055	1
24	Hydraulic Cylinder	15001871	1
25	'O' Ring	B6055	1
26	Hydraulic Piston	15001872	1
27	'O' Ring	B6056	1
28	Spring	B1791	6
29	Thrust Plate	18000214	1
30	Bridge Support Ring	15001868	1
31	Bearing	18000207	1
31A	Washer	15003826	1
32	Cap Screw M8 x 25	B0687	6
33	Retaining Ring	15001865	1
34	Thrust Plate	15001863	1
35	Cap Screw M6 x 16	B0679	1
36	Bearing	18000208	1
37	Bearing	B3431	1
38	Clutch Pressure Plate	15001864	1
39	Cap Screw M5 x 20	B0677	6
40	1/8" BSP Dowty	B2777	1
41	Hose Assembly	18000526	1
42	Hose Asembly	18000526	1

Item	Description	Part No.	No. Off
43	Hose Asembly	18000526	1
44	Hydraulic Motor	B3320	1
44A	Gearbox	B6397	1
45	Base	15003096	1
46	Bearing	18000007	2
47	Spacer	15001878	2
48	Output Gear Assembly	18000201	1
49	Washer	B1223	8
50	Crown Stop	45002577	8
51	Spacer	45002613	8
52	Spring	B7057	8
53	Washer	45002576	16
54	Output Gear Assembly	18000201	1
55	Drive Shaft	15001869	1
56	Washer	15000605	1
57	Spirolox Clip	B6129	1
58	Circlip	B2075	1
59	Dowel	15000619	2
60	Pin	15001882	2
61	Gear Spindle	15001870	2
62	Bearing	15000019	17
63	Washer	15001556	2
64	Ratchet Gear Support	15001861	1
65	Cap Screw M10 x 20	B0691	4
66	Thrust Bearing Support	15001862	1
67	Stainless Steel Balls	B1656	57
68	Washer	15000568	1
69	Bearing	15010007	2
70	Cap Screw	B0693	10
71	Ratchet Gear	15001858	1
72	Washer	15001879	1
73	Pawl Plate	15001859	1
74	Cap Screw M8 x 35	B0760	6
75	Retainer Plate	15001883	1
76	Pawl	15000577	4
77	Pawl Spring	1249/7	4
78	Cap Screw M5 x 10	B0675	3
79	Location Screw	15001276	3
80	Clutch Support Ring	15001867	1
81	Clutch Gear	15001866	1
82	Drive Plate	15001860	1
83	Clutch Plate Plain	15001874	3
83A	Clutch Plate Bonded	18000216	4
84	Dowel	15001880	2
85	Bleed Nipple	B6007	1



# NOTES

---





**LEWMAR®**

[www.lewmar.com](http://www.lewmar.com)

© Copyright 2003 Lewmar Ltd. All rights reserved.

B2312