

# 28 ST Compact Motor™ Electric Above Deck

2 speed manual, variable speed electric, 12VDC



**Andersen Powered Winch: RA2028015100, RA2028005100**  
28ST ABOVE DECK COMPACT MOTOR™ ELECTRIC  
2 speed manual, variable speed electric, 12VDC

## Product Information:

Power Ratio 1st speed = 9.5:1, 2nd speed = 28.6:1  
Gear Ratio 1st speed = 1.3:1, 2nd speed = 4.0:1  
Maximum Working Load 600kg (1320lb)  
Maximum Pulling Load 575kg (1268lb)  
(when electrically operated)

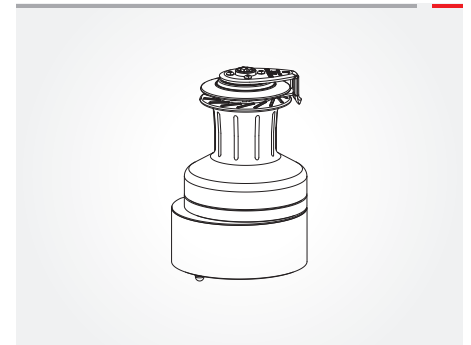

## Physical Dimensions:

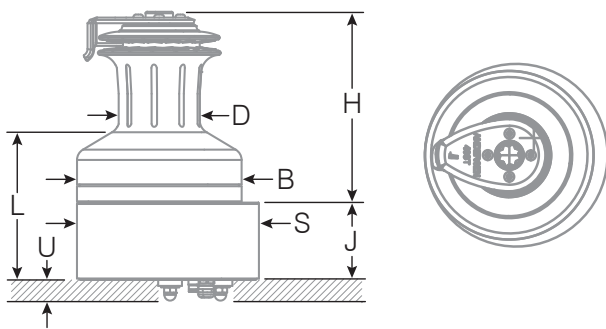

Rope Size.....8-14mm (5/16 - 9/16")  
Drum Ø D.....70mm (2 3/4")  
Base Ø B.....125mm (4 15/16")  
Height H.....161mm (6 5/16")  
Line Entry L.....150mm (5 15/16")  
Motor Depth U.....28mm (1 1/8")\*  
Motor Ø S.....200mm (7 7/8")  
Motor Height J.....85mm (3 3/8")  
Weight.....16kg (35.3lb)

\*Extensions available to suit thicker decks.  
Full installation dimensions can be found in the Product Manuals - available to download at [www.andersenwinches.com](http://www.andersenwinches.com)

## Wiring Diagram:

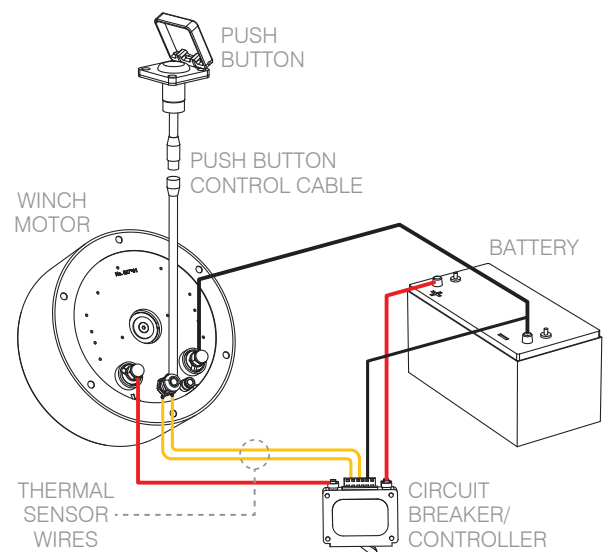

Motor units are supplied with installation manual, push button, 1000mm (39") push button control cable, circuit breaker/controller and terminal extensions. A secondary push button RA866000, RA866010 or RA866020 can be added to the installation only if specified with the original order, and may not be retrofit.

## Electrical Installation:

WIRE LENGTH <sup>1</sup>	WIRE SIZE	ADDITIONAL BATTERY CAPACITY PER WINCH <sup>2</sup>	MINIMUM BATTERY BANK CAPACITY <sup>3</sup>
0-10m (10-33ft)	25mm <sup>2</sup>	54Ah	150Ah
10-15m (33-49ft)	35mm <sup>2</sup>		
15-20m (49-65ft)	50mm <sup>2</sup>		

- Wire length = length from battery to motor and back to battery.
- This is the minimum additional Ah (Ampere hours) battery capacity that will be required to run one winch. Assuming a single winch, used for of 15 minutes (0.25hr) per day at a load of 1/2 MWL = 72A. This equates to an Ah figure of 18Ah. The number of Ah for all other electrical equipment must be added to this figure to determine the Ah requirement of the total battery bank capacity. A good rule of thumb is to use
- 3 x this total Ah figure as the minimum additional battery capacity for your battery bank. We recommend you contact a qualified marine electrician for advice.
- This is the minimum recommended battery bank capacity to ensure minimum 10.5V is maintained in 12V systems, and 21V in 24V systems at start up current. Based upon battery CCA value at -18C and assuming fully charged batteries and no losses in wiring and connections.

## Performance:

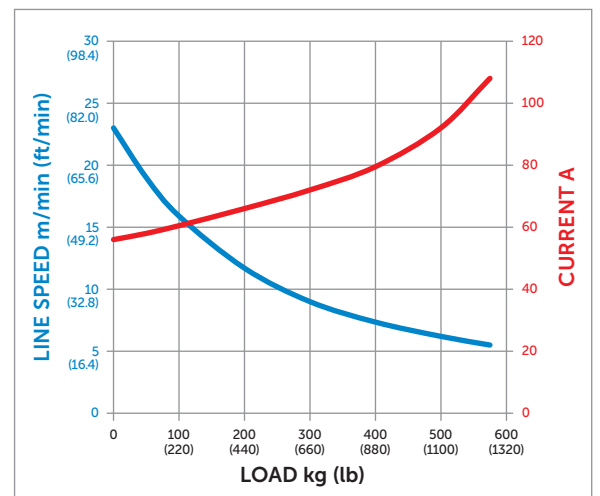

The motor will cut-out at pre-determined current and temperature limits.

