

Trogear Bowsprits Installation Questionnaire

Your answers to the following questions will help us plan your Trogear Bowsprit installation

1. What is the make, model and year of your yacht?

2. What free flying sails (Spinnaker, Code0 etc.) are you planning to use and what are their sizes?

3. What kind of sailing do you engage in? Racing, cruising, a mix of the two?

4. Do you have a bow roller?
 - a. If you have a bow roller, is it a double or single channel?
 - b. If you have a bow roller, do you sail with the anchor in place?
 - c. overall extension past bow

5. If planning to mount on the bow roller, please provide measurements:
 - a. width at the forward most point
 - b. width near the head stay.



6. Do you have a rub rail? If yes, please provide how far it protrudes past the hull.
7. Is the inside of your bow clear from obstruction for a through hull installation?
8. Do you have a preference for the length of the sprit past the bow?
9. Please provide photos of the bow of your yacht from the side and top.
10. To estimate mounting location of the sprit, please provide the following measurements of your bow:
 - a. Across the deck at 50cm (24") from the tip of the bow
 - b. Across the deck at 25cm (12") from the tip of the bow

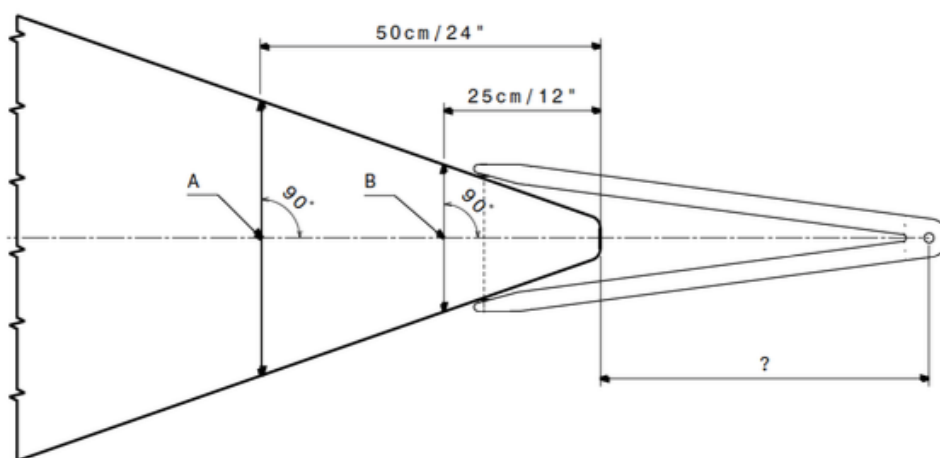

N.B. The more images we can get for each/any of the above points the more confident we can be in recommending the right installation option for you.