

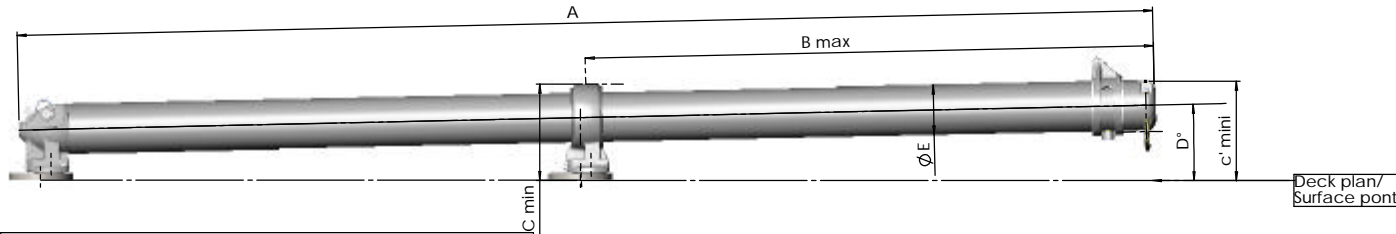

Bowsprit dimensions / Encombrement de la gamme bout-dehors

BOWSPRIT INSTALLATION ON DECK / MONTAGE BOUT DEHORS SUR PONT



On deck / Sur pont				
Cotes (mm)	Ø70	Ø80	Ø90	Ø100
A	1600	1800	1900	2000
B	800	900	950	1000
C mini	135,6	135,6	155,6	155,6
C' mini	139,5	151,9	159,8	166
D°	1,3°	1,2°	1,1°	1,1°
ØE	70	80	90	100

BOWSPRIT FITTING
EQUIPEMENT BOUT-DEHORS

BACK END FITTING / EMBOUT ARRIERE

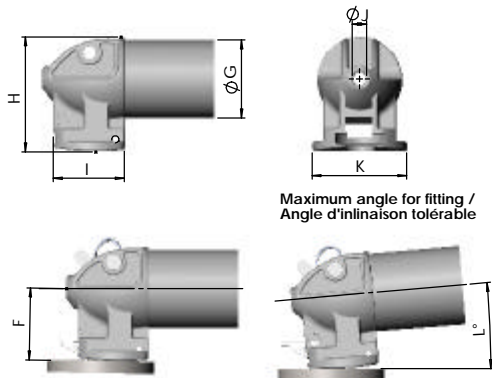

Maximum angle for fitting /
Angle d'inclinaison tolérable

CENTRAL COLLAR / COLLIER CENTRAL

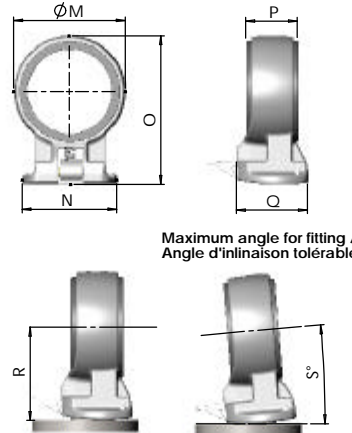

Maximum angle for fitting /
Angle d'inclinaison tolérable

FURLER FITTING RING
/ ATTACHE EMMAGASINEUR

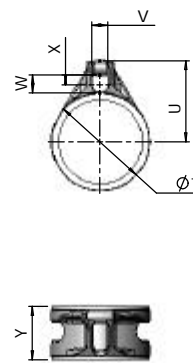

FRONT END FITTING /
EMBOUT AVANT

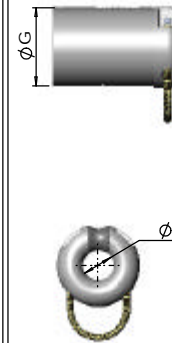

Bowsprit equipement / équipement bout-dehors				
Cotes (mm)	Ø70	Ø80	Ø90	Ø100
Back end fitting / Embout arrière				
F	61,8	61,8	72	72
ØG	66	66	84	84
H	97	97	117,5	117,5
I	60	60	60	60
ØJ	12	12	14	14
K	80	80	80	80
L°	5°	5°	3°	3°
Central collar / Collier central				
ØM	93	93	115	115
N	80	80	80	80
O	125,6	125,6	146	146
P	44	44	44	44
Q	60	60	60	60
R	78,6	78,6	88,5	88,5
S°	5°	5°	3°	3°
Furler fitting ring / Attache emmagasineur				
ØT	83	93	103	113
U	68,5	83,5	93,5	98,5
V	13,5	19	19	19
W	15	19	20	20
X	8,25	12	13,9	13,8
Y	45	45	55	55
Front end fitting / Embout avant				
ØZ	25,6	25,6	29,5	29,5

DECK FITTING
EQUIPEMENT FIXATION

WORKING DECK FITTING / PLOT TRAVAIL

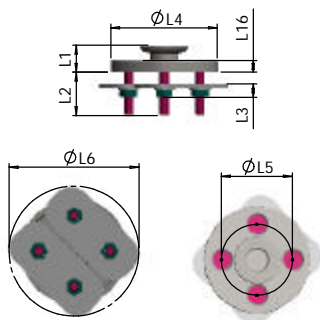

STEM HEAD FITTING / OPTION ADAPTATION DAVIER

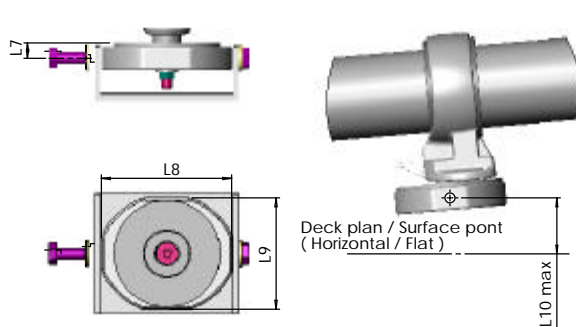

PARKING DECK FITTING /
PLOT PARKING

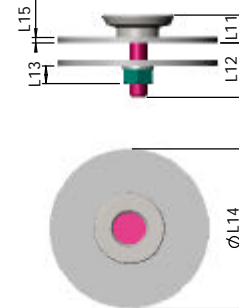

Deck fitting / Equipement de fixation pont				
Cotes (mm)	Ø70	Ø80	Ø90	Ø100
working deck fitting / plot travail				
L1		22,75		
L2		39		
L3		12,3		
ØL4		90		
ØL5		60		
ØL6		109,7		
Stem head fitting / Adaptation Davier option				
L7		13		
L8		110		
L9		94		
L10 max	44,5	53,5	28	28
Parking deck fitting / Plot parking				
L11		15,75		
L12		32,7		
L13		13,3		
Ø L14		90		
L15		3		
L16		10		