

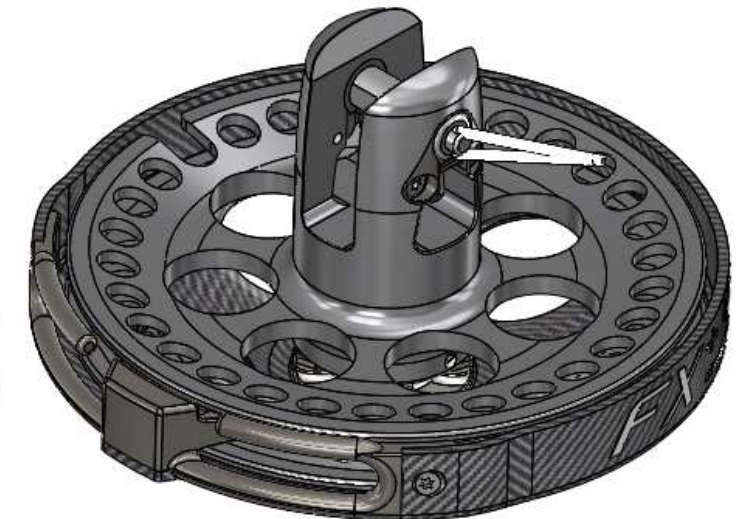

Emerillon équipé: 498g

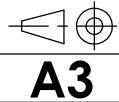

Emmagasineur équipé: 1026g

Poids Calc: 1524 g

REV.	DATE	AUTEUR	APPROUVE	DESCRIPTION
				PC + EMER FX+ 4500
				 A3 Ech: 1:2
				 facnor ENROULEURS DE VOILES
				FACNOR S.A. Parc d'Activités - B.P. 222 F-50550 SAINT-VAAST-LA-HOUGUE tel. +33 (0)2 33 88 50 22 fax. +33 (0)2 33 23 14 27
				Ce plan est la propriété intellectuelle de FACNOR SA. Il ne peut être divulgué à des tiers sans notre autorisation écrite, ni servir à d'autres fabrications.
				Date: 22/05/2014 Tol. Gén.: +/-0.15 Etude: 22052014JF01 Auteur: JFirmin Matière: -- Indice: Finition: --
				Usiné: Repris: PoliM: