

Note:
 The PE Plastic base is intended for fitting on site and can be either drilled for mounting screws from above. 6mm screws with nuts and washers are recommended for secure mounting.

135° White
 Double Function
 Stern and Anchor

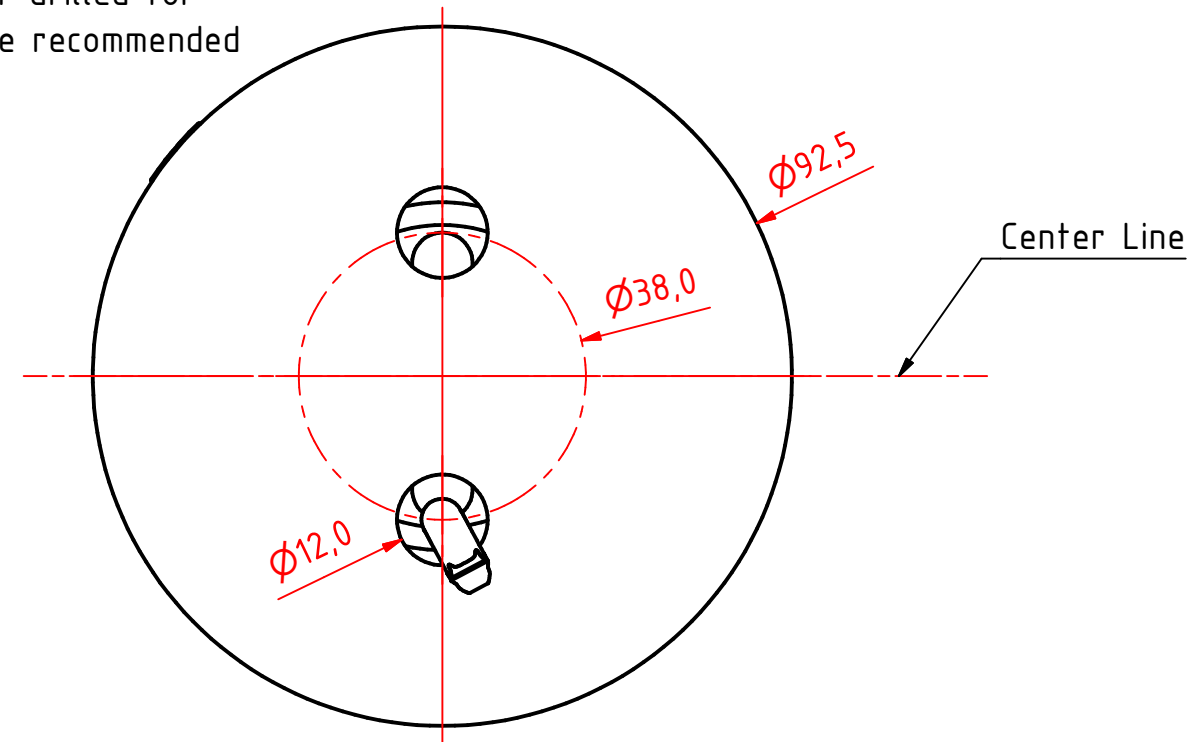
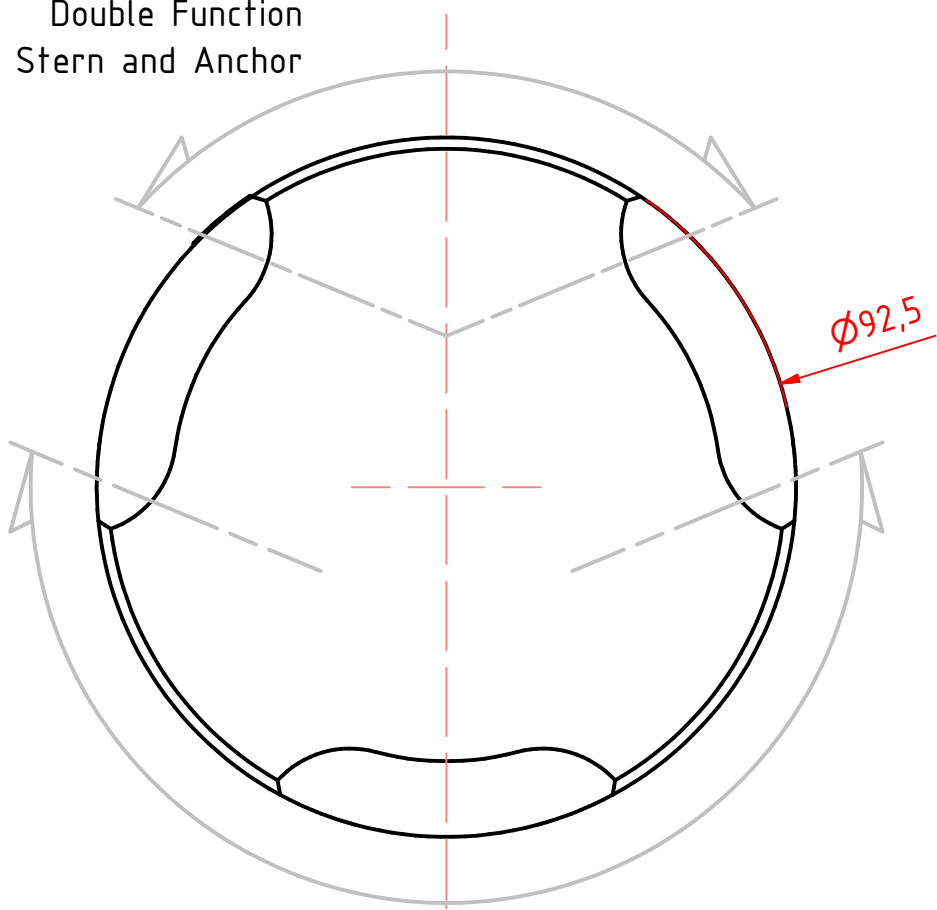

225° Masthead Only

CL



201-020 2nm masthead, anchor, on a 400-038 PE std base. Power Boat light			
DRAWING NO.: 201-020GA	REV. NO.: 0	SIZE: A3	DRAWN BY: Sergio
SCALE: 1:1	TOLERANCES: DS/ISO 2768-f	REVIEWED BY: PHC	CREATION DATE: 24-04-2018
MATERIAL DESCRIPTION: EN 6082, Acrylic, PE (20µ) Silver anodized according to EN ISO 7599 (50µ) Black anodized according to MIL-A 8625F			
This Drawing, and the information within, is the property of Lopolight ApS and may not be used in any form without express permission there from. Lopolight reserves the right to change this drawing and assumes no liability for the information communicated herein. Use of dimensions and other information in this drawing is at the users own risk.			

LOPOLIGHT
 Lopolight ApS
 Bakkegaardsvej 513
 DK-3050, Humlebaek
 Denmark
 www.lopolight.com
 Tel:(+45) 32 48 50 30 Fax:(+45) 32 48 50 32
 info@lopolight.com

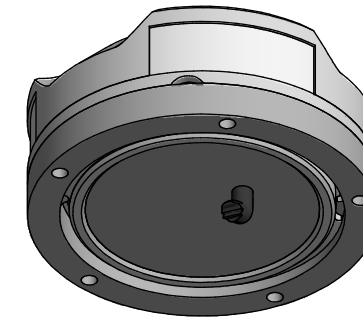
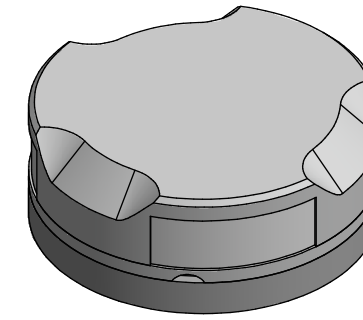
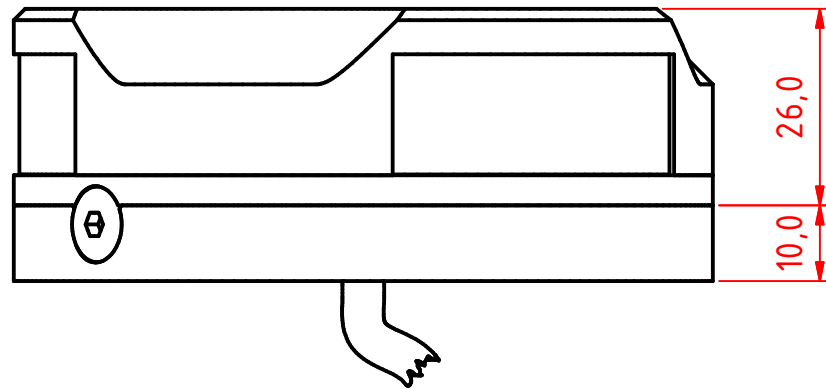
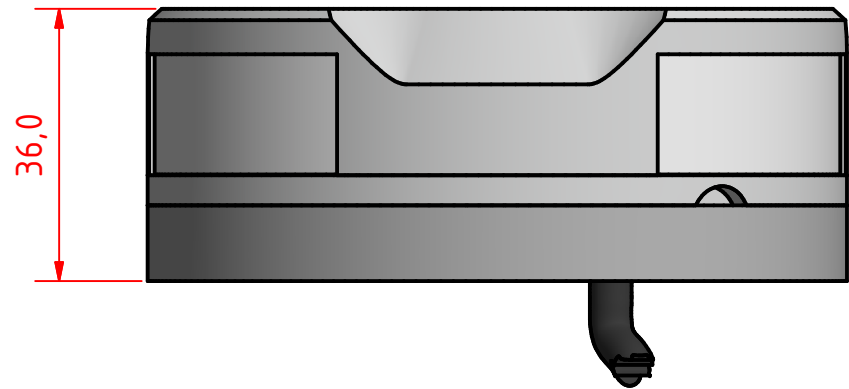

135° White
Double Function
Stern and Anchor

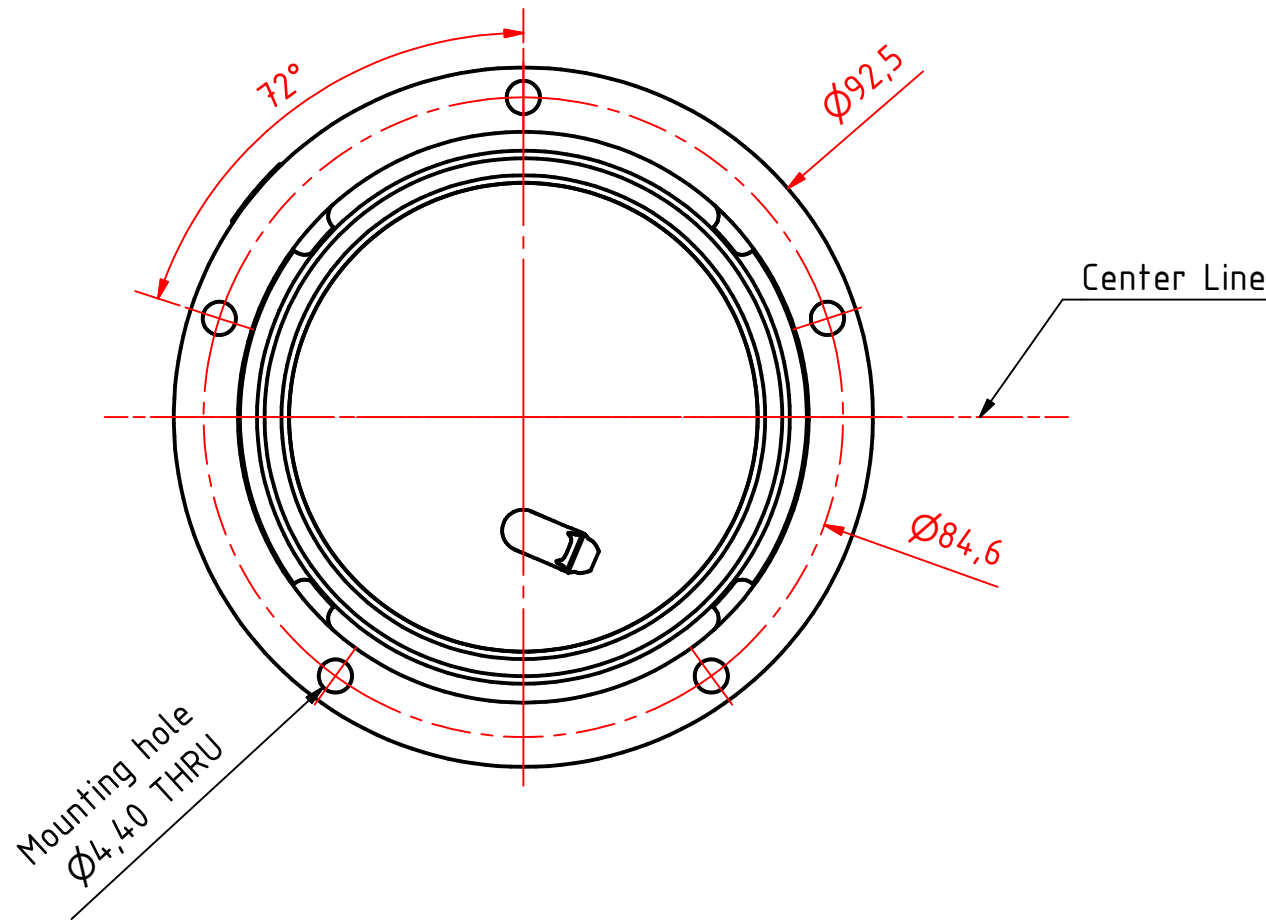
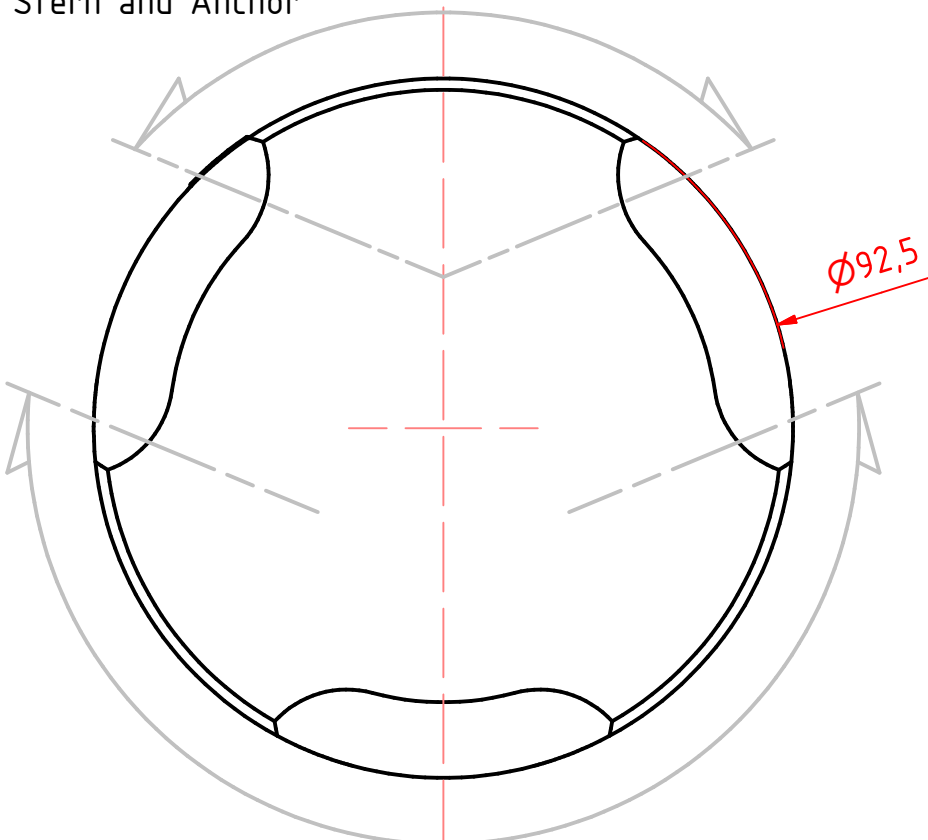

225° Masthead Only

CL

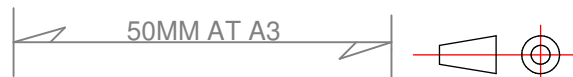

201-020 2nm masthead,anchor, on a
400-036 Ultra Low profile base. Power Boat
light

DRAWING NO.:	REV. NO.:	SIZE:	DRAWN BY:
201-020IA	0	A3	Sergio

SCALE:	TOLERANCES:	REVIEWED BY:	CREATION DATE:
1:1	DS/ISO 2768-f	PHC	24-04-2018

MATERIAL DESCRIPTION:
EN 6082, Acrylic, PE (20µ) Silver anodized according to EN ISO 7599
(50µ) Black anodized according to MIL-A 8625F

This Drawing, and the information within, is the property of Lopolight ApS and may not be used in any form without express permission there from. Lopolight reserves the right to change this drawing and assumes no liability for the information communicated herein. Use of dimensions and other information in this drawing is at the users own risk.



Lopolight ApS
Bakkegaardsvej 513
DK-3050, Humlebaek
Denmark

www.lopolight.com

Tel:(+45) 32 48 50 30 Fax:(+45) 32 48 50 32
info@lopolight.com