

ULTRASONIC SPEEDO sensor

Product reference : 90-60-479

REV 1



USER GUIDE and INSTALLATION GUIDE

nke - Sailing competition

Z.I. Kerandré – Rue Gutenberg – 56700 HENNEBONT- FRANCE
<http://www.nke.fr> – N°indigo 0 892 680 656 : 0,34€/min.

TABLE OF CONTENTS

1	USE	3
1.1	PRESENTATION.....	3
1.2	LIST OF CHANNELS DISPLAYED	4
1.3	ALARMS SETTING	4
1.4	FILTERING OF THE CHANNELS.....	5
1.5	CHOICE OF THE UNIT	5
1.6	ZERO SETTING OF THE DAILY LOG AND TOTAL LOG.....	5
1.7	TECHNICAL SPECIFICATIONS	5
1.8	DIAGNOSTIC OF 1 ST LEVEL TROUBLESHOOTING.	6
2	USE OF THE <i>ULTRASONIC SPEEDO</i> ON NMEA OR <i>PADDLEWHEEL</i> OUTPUT	7
2.1	CHARACTERISTICS OF THE NMEA OUTPUT	7
2.2	CHARACTERISTICS OF THE <i>PADDLEWHEEL</i> OUTPUT.....	7
2.3	CONNECTION OF THE NMEA OR <i>PADDLEWHEEL</i> OUTPUTS	8
2.4	TEMPERATURE	8
3	SENSOR CALIBRATION	9
3.1	PRINCIPLE OF CALIBRATION :	9
3.2	SETTING PROCEDURE OF THE CALIBRATION COEFFICIENT :	9
4	INSTALLATION	10
4.1	PACKING LIST	10
4.2	LIST OF ACCESSORIES.....	10
4.3	SPECIFIC TOOLS REQUIRED FOR THE INSTALLATION	10
4.4	CHOICE OF THE LOCATION	10
4.5	INSTALLATION OF THE THROUGH-HULL	12
4.6	INSTALLATION OF THE <i>ULTRASONIC SPEEDO</i> SENSOR	13
4.7	INSTALLATION OF THE SAFETY WIRE.....	13
4.8	ADAPTER FOR THE OLD <i>NKE</i> THROUGH-HULL : 31-36-002	13
4.9	ELECTRICAL CONNECTION TO THE <i>TOPLINE LOCH SOUNDER INTERFACE</i>	14
5	MAINTENANCE	14
5.1	RECOMMENDATIONS	14
5.2	AT PORT, HOW TO REMOVE A SENSOR FROM THE THROUGH-HULL ?.....	14

1 USE

1.1 Presentation

The **ULTRASONIC SPEEDO** sensor is a measuring instrument that provides speed and distance covered by the ship, as well as water temperature. Its ultrasound technology allows it to achieve a level of accuracy and reliability superior to standard paddlewheel speedometers. In the absence of any moving mechanical parts, no maintenance is required once it is put in operation.

Two types of installation are possible :

- The **ULTRASONIC SPEEDO** is connected to the **TOPLINE** bus of your installation, via **the loch sounder interface**.
- As an autonomous sensor, with a 12V power supply, the **ULTRASONIC SPEEDO** provides the information on speed, via an **NMEA0183** output or a **Paddlewheel** output.

The **ULTRASONIC SPEEDO** is installed on the hull of the boat, using a through-hull.

Architecture of the installation

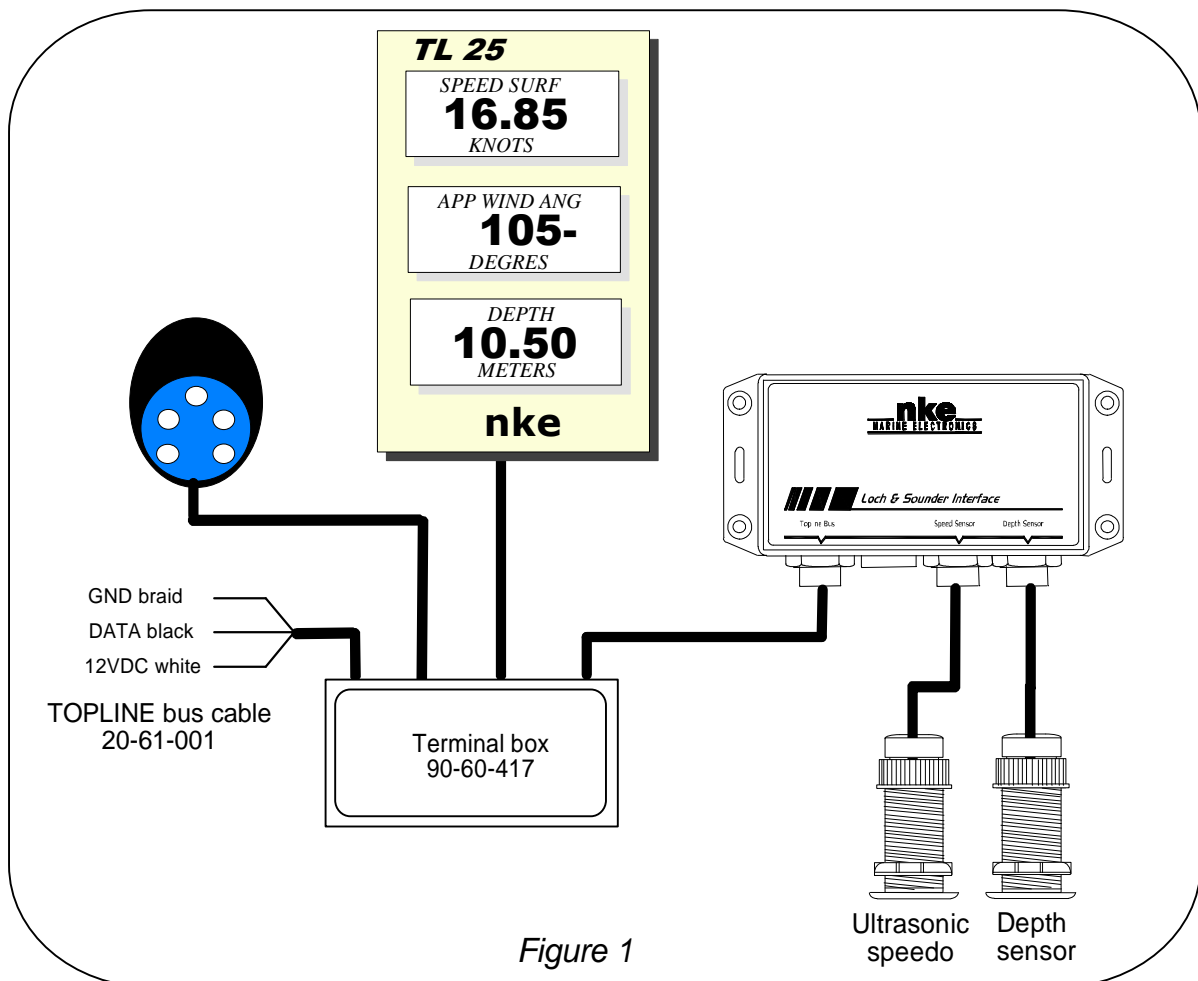

IMPORTANT :

- Read this guide entirely before starting the installation.
- Some products, for cleaning, painting or other, contain powerful solvents, which can severely damage the plastics and O-rings of the sensors.
- Plastic through-hulls are recommended for installation on fibre, aluminium or metal hulls. For an installation on wood hull, use a bronze through-hull.
- For channel setting, please refer to your **TOPLINE** display user guide.

1.2 List of channels displayed

The **ULTRASONIC SPEEDO** sensor, connected to the **nke TOPLINE bus**, automatically creates the channels below. They are accessible using the displays of the **TOPLINE** range..

Channel	Display	Unit
Boat speed	Boat spd 0.00 Kt	km/hr or knot
Daily log	Trip log 0.00 NM	Nautical mile
Total log	Total log 0.00 NM	Nautical mile
Bus voltage	Bus volt 12.5 v	Volt
Water temperature	Water temp 15.4 °	°C or °F

1.3 Alarms setting

The setting of an alarm enables you to monitor the value of a channel. When the preset threshold is exceeded, a warning message is displayed and an audible alarm is activated. For example, you can set an upper threshold and a lower threshold on the **boat speed** channel.

The upper alarm is activated when the display is higher than the programmed threshold.

The lower alarm is activated when the display is lower than the programmed threshold.

To cancel the alarm of a channel, enter the value **0** in the upper alarm and the lower alarm.

Thus, the setting of an alarm on the **speed, bus voltage or water temperature** channels will allow you to supervise your installation effectively, as well as the good operation of your ship.

To activate the alarms, please refer to the user guide of your display.

CAUTION : The **water temperature** channel has a distinctive feature. To cancel the alarm of this channel, enter the value **0**, when the unit is the degree Fahrenheit, or **-17.7**, when the unit is the degree Celsius.

1.4 Filtering of the channels (damping)

The level of **filtering** of a channel determines the frequency of update of the data displayed.

For example, in rough sea when the ship moves significantly, it is useful to increase the filtering of the speed channel to stabilise the value displayed. Conversely, in calm sea, low filtering will be preferable to obtain a fast response of the display.

Filtering is adjustable between **1** and **32**, and the default value is **8**. The lower this value, the higher the frequency of update.

Please refer to the user guide of your display to carry out the filter setting.

1.5 Choice of the unit

You have the option to choose the following display units :

- Speedometer : in knots or in km/hr,
- Water temperature : in degree Fahrenheit or in degree Celsius.

Please refer to the user guide of your display to carry out this change of units.

1.6 Zero setting of the daily log and total log

The channels **trip log** and **total log** are at your disposal on your display.

You will use the **trip log** to count the number of nautical miles completed during a sailing leg. The value is kept in memory when the power supply of your installation is cut off. Resetting the **trip log** channel to zero will allow you to count the number of nautical miles of the following sailing leg.

The **total log** indicates the number of nautical miles completed since the installation of your **loch sounder interface**. Only a complete initialisation of your **loch sounder interface** allows to reset the **total log** to zero. It is performed by initialising the **boat speed** channel.

CAUTION : If you perform a complete initialisation, you also initialise the settings of **filtering, calibration, alarm, offset, trip log and total log**. In that case, you apply the default factory settings to the **loch sounder interface** : filtering = **8** ; calibration coefficient = **1** ; Offset = **0**.

To reset the **trip log** or the **total log** to zero, please refer to the user guide of your display.

1.7 Technical specifications

- Tightness of the sensor : IP67.
- 10 meter cable, fitted with connector.
- Weight : 500 g (cable included).
- Operating temperature : -10°C to +50°C.
- Storage temperature : -20°C to +60°C.
- Speed measurement range : 0.3 to 50 knots.
- Resolution : 1/100th of a knot.
- Accuracy < 1% for laminar flow.
- Temperature measurement range : 0°C to +50°C.

1.8 Diagnostic of 1st level troubleshooting.

This chapter can help you rapidly resolve minor problems which do not require the intervention of a specialist. Before contacting technical support, please check the troubleshooting table below.

The **ULTRASONIC SPEEDO** sensor comprises a two-colour LED that indicates the state of the sensor :

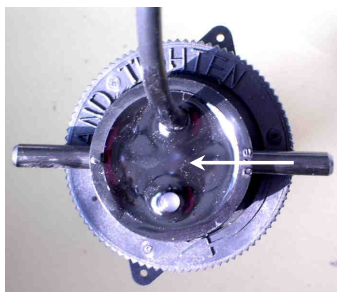

The table below provides you with the operating state or the type of fault of the **Ultrasonic Speedo** according to the state of the LED :

LED state	operating state or corresponding fault
LED unlit	- Sensor power off or out of order.
green LED	
1 flash ▲ 1.5s period	- Sensor power on, pending locking (detection of moving particles) - or speed close to 0 or negative - or sensor off-centre or wrong way round - or very shallow seabed (<1m) hard and flat
2 flashes ▲▲ ▲▲	- Sensor locked on one speed, poor level of particles (pure and calm water)
3 flashes ▲▲▲ ▲▲▲	- Sensor locked on one speed, average level of particles
Continue	- Sensor locked on one speed, perfect quality of measurement
Red LED	Faulty sensor
1 flash ▲ 1.5s period	- Sensor power on, pending locking (no moving particles) Occasional occurrence if extremely calm water with no current.
2 flashes ▲▲ ▲▲	- Sudden unlocking at full speed, possible causes are : <ul style="list-style-type: none"> • very shallow seabed (<1m) hard and flat, • particles no longer detected (lift or cavitation air layer), • crossing of a very turbulent wake (saturation of air bubbles, eddies), • Non laminar flow (beneath the hull of very long ships with high tonnage and speed). • Angle between the flat surface of the sensor and non-parallel flow.
3 flashes ▲▲▲ ▲▲▲	- Abnormal reflectivity of the ultrasounds on one of the transducers. Air layer too significant (cavitation). Possible occurrence if the sensor is in the air layer, or if there are stagnant air bubbles beneath the hull.
4 flashes ▲▲▲▲ ▲▲▲▲	- Abnormal reflectivity of the ultrasounds on all the transducers (Same as 3 flashes)
4 flashes ▲▲▲▲ ▲▲▲▲	- Measurement disrupted by abnormal ultrasound or electrical transitions (filter the disrupting equipment : high power alternator, arcs of a power sweep engine, harmonics of a high power sounder, etc.)
6 flashes ▲▲▲▲▲▲ ▲▲▲▲▲▲	- Measurement disrupted by an abnormal ultrasound or electrical carrier (isolate the disrupting equipment : power supply or battery charger with faulty cutting, SSB transmitter in aviation band).
Continuous	- self-diagnostic error : product out of order
red and green LED	
Flashing fast	Ongoing firmware download via the Toplink maintenance software.
Flashing slow	Flash memory checksum error : must be reprogrammed via the Toplink maintenance software.

The problem may also come from the **Loch Sounder Interface** : please also refer to the 33-60-450 user guide. If you do not manage to solve the problem, please contact your distributor.

2 USE OF THE *ULTRASONIC SPEEDO* ON NMEA OR *PADDLEWHEEL* OUTPUT

The *ULTRASONIC SPEEDO* contains a *NMEA* output, and a *Paddlewheel* output, which deliver a signal identical to that of a paddlewheel. Thus, without using a *TOPLINE nke* bus, you can connect the *ULTRASONIC SPEEDO* sensor directly into your electronic navigation system.

2.1 Characteristics of the NMEA output

The two NMEA frames below are delivered by the *ULTRASONIC SPEEDO*. These frames comply with the NMEA 0183 V2.30 standard (or previous version) and their format is : 4,800 bauds / 8 bits with bit 7 at 0 / 1 start bit and 1 stop bit, with or without checksum.

`$VMVHW,,,,,03.70,N,,*36`

 \ \ Checksum
 \ Speedo in knots

`$PNKEU,293,05,11V10F25,11,3,10A23,12,2,11*hh` (reserved nke)

2.2 Characteristics of the *Paddlewheel* output

The *Paddlewheel* output delivers a 0/12VDC signal, the frequency of which is proportional to the speed of the ship : 4.5Hz per knot.

- Supply voltage : 10VDC to 16VDC
- Consumption : 35mA.

Please note that for *Paddlewheel* operation, we recommend that sensor filtering be set to the minimum : see paragraph 1.4.

2.3 Connection of the NMEA or *Paddlewheel* outputs

In this configuration, the connector placed at the end of the cable can no longer be used :

- Cut the end of the cable as close as possible to the connector,
- Cut the cable sheath and strip the conductors,
- Connect the sensor to your electronic system according to the table below :

Wire identification	Black cable 5 conductors
+12V	Red wire
Earth	Braid
NMEA + output	Orange
PADDLEWHEEL output	Green
Test	Black

2.4 Temperature

The **ULTRASONIC SPEEDO** is also fitted with a temperature sensor. The sensor is a thermistor of the CTN type, the characteristics of which are : $R=10\text{Kohm}$ at 25°C $\pm 2\%$ ($\beta=3977 \pm 0.75\%$, floating potentials, capacitance to earth : 10nF).

Wire identification	Black cable 5 conductors
CTN A	Brown
CTN B	White

2.5 Test

A test allows to verify the coherence of the speed which is displayed on the board displays with the frequency provided on the « PADDLEWHEEL » output or the signal provided on the NMEA output.

To start this test, the black wire of the sensor must be connected to the ground before to power on the sensor. 18 seconds after the Ultrasonic Speedo sensor is powered on (black wire still connected to the ground) the sensor executes 3 test cycles during 24 seconds with a transmission of the following sequence on both NMEA and PADDLEWHEEL outputs :

- 8 seconds at 10 knots (45 Hz)
- 8 seconds at 20 knots (90 Hz)
- 8 seconds at 0 knot (0 Hz)

At the end of the test you must disconnect the black wire and insulate it.

3 SENSOR CALIBRATION

Every *nke* sensor is adjusted at the factory. However, a calibration is required to adapt to the specificities of your ship and to obtain an optimum measurement accuracy. Follow the calibration procedure below, by visualising the settings on a display. To perform these settings, please refer to the user guide of your display.

3.1 Principle of calibration :

It consists in executing a course with your ship, with a true distance, **D** miles, that is known, and taking down the number of miles indicated by the log, **L** miles. Then, you calculate the calibration coefficient according to the formula : **D / L**.

Example :

The course measured on the chart between two sea-marks is : **D = 1.43 MILES**

The number of miles indicated by your log for this course is : **L = 1.10 MILES**

The calibration coefficient calculated is $1.43 / 1.10 = 1.30$.

To ensure the calibration is effective, you will execute a return journey, to cancel the effects of the current, and in excess of 1 Nautical mile.

3.2 Setting procedure of the calibration coefficient :

To achieve a successful calibration, follow the indications below :

- Sail with the engine, on calm sea, with no wind and at slack low or high water.
 - Execute a return journey over a perfectly known distance.
1. Select the sub-channel **calib offset** of the channel **surface speed**. By default this coefficient is **1.00**. If that is not the case, enter the value **1.00**
 2. Select the channel **Daily log** of the display and set the log to zero.
 3. Execute a return journey between the two selected sea-marks.
 4. Read the total distance (return journey) measured by the log.
 5. Perform the required calculation in order to determine the calibration coefficient **D / L**.
 6. Select the **calib coef** parameter of the **surface speed** channel once again.
 7. Enter the new calibration coefficient calculated and validate by pressing the **enter** key. The new setting will be saved to the memory.

CAUTION : The **calib coef** parameter is a multiplier coefficient. This value must never be equal to zero. By default this coefficient is set to **1.00**. If it is not the case, before starting a calibration enter the value **1.00**.

4 INSTALLATION

4.1 Packing list

- The **ULTRASONIC SPEEDO** sensor comes equipped with a 10 metre cable, a waterproof connector, sealing joints and the clamping nut.
- User and installation guide

4.2 List of accessories

- Installation kit of the loch through-hull, stopper and tube of silicon grease : 31-35-001
- Adapter for through-hull fitting with a diameter : 2"
- O-ring Øint 28 : 25-60-004
- O-ring Øint 35.5 : 25-60-037
- O-ring Øint 37.69 : 25-60-039

4.3 Specific tools required for the installation

The drilling of the hole for the through-hull is performed using a Ø 51mm crown saw drill bit fitted with a guide pin.

4.4 Choice of the location

The choice for the location of the speedometer log sensor is crucial to achieve optimal performances. Turbulences caused by the water flow under the ship can significantly disrupt the operation of the speedometer.

The sensor must be :

- as vertical as possible, not more than 10° off the vertical,
- as close as possible to the axis of the ship,
- sufficiently far from the keel,
- always immersed, no matter what the heel,
- away from any source of electrical disturbance,
- accessible so it can be cleaned from the inside of the ship.

It is imperative that the water streams get to the sensor unperturbed.

On a sailing boat : the ideal position of the sensor is in front of the keel, along the axis of the ship.

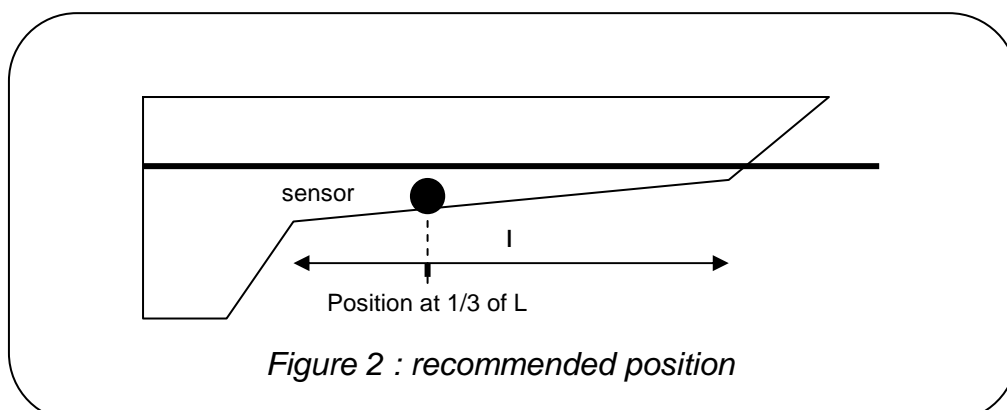

On a motorboat : the sensor must be approximately 50 cm back from the squat limit. It may be necessary to prepare a 10 to 15 mm streamlined plate so that the sensor is located beyond the turbulent water layers.

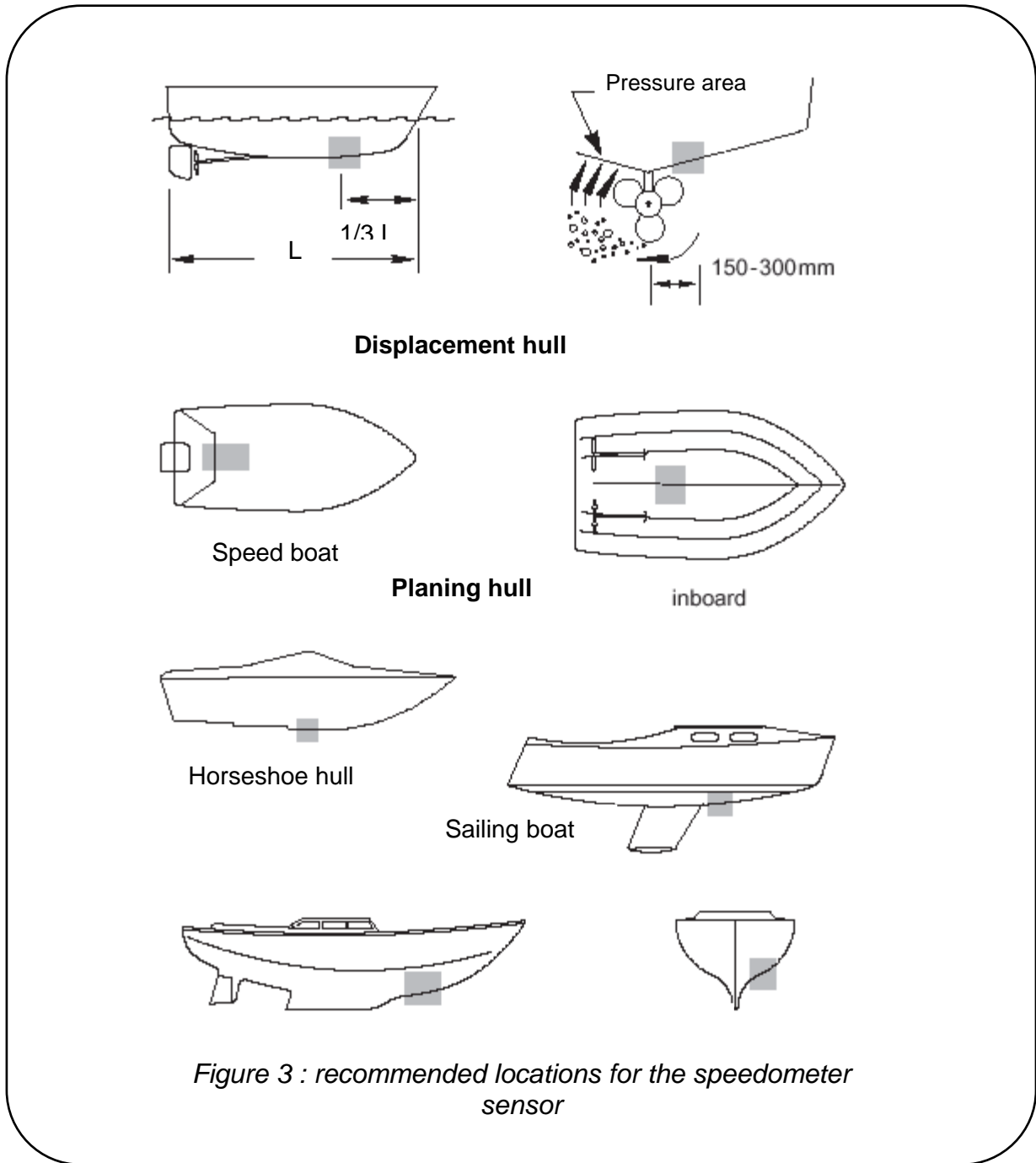

4.5 Installation of the through-hull

Once the location of the sensor is determined, follow the procedure below :

- From the inside of the ship, drill the pre-drilling hole, then from the outside, drill a 51 mm diameter hole using the crown saw.
- Degrease the hull.
- Coat the flange of the through-hull with sealing paste. Place the through-hull in position.
- Inside the ship, lay some sealing paste around the through-hull.
- Position the through-hull by orienting the foolproof spigot towards the bow of the ship (see figure 4). Similarly, on the outside face of the through-hull, an arrow indicates the direction : position this arrow towards the bow of the ship.
- Screw the nut and tighten **moderately**.
- Grease the stopper and screw it onto the through-hull.
- Leave to dry for over 12 hours.

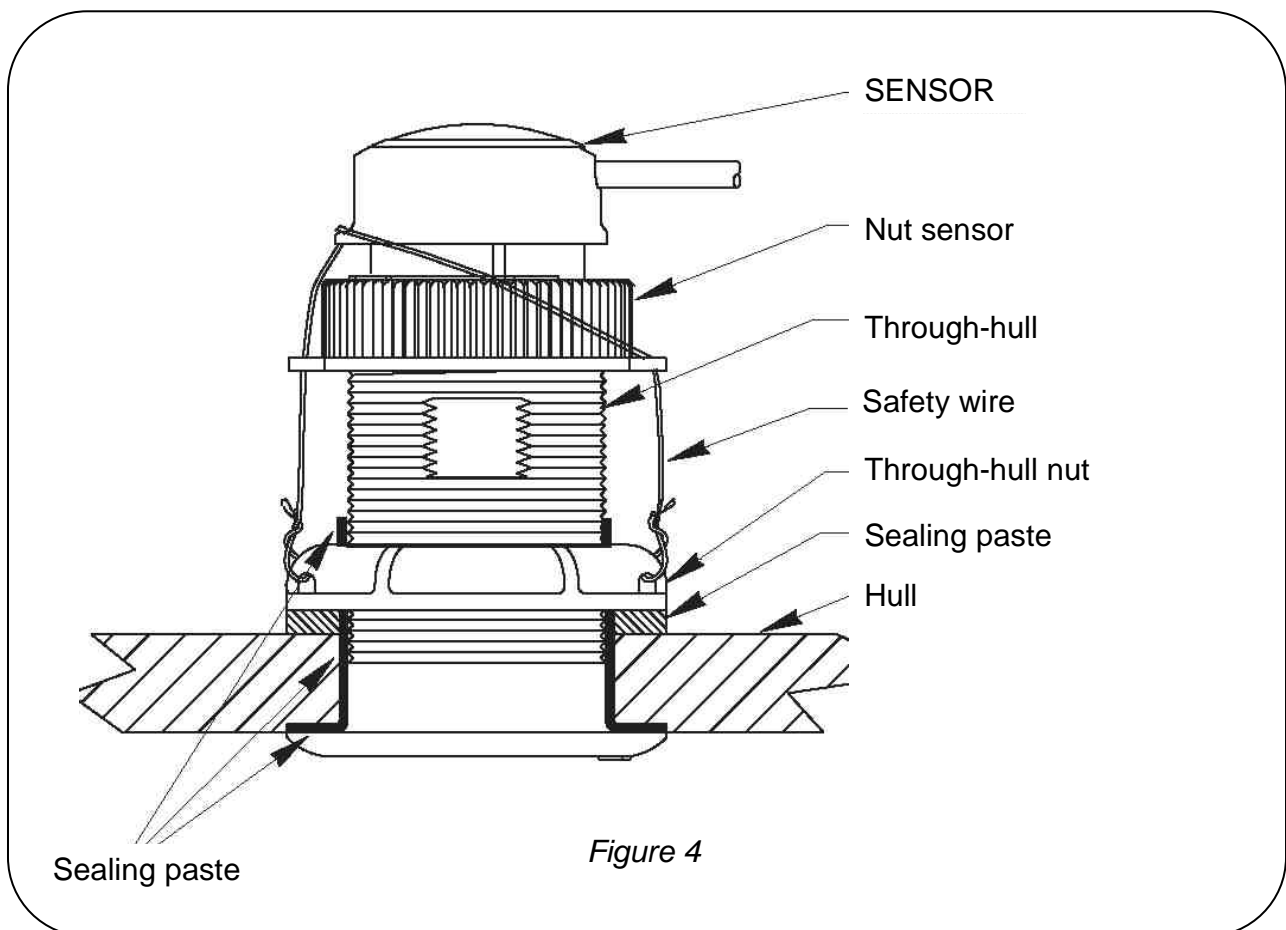

Note : a flat joint is supplied with the through-hull, for the water tightness between the hull and the through-hull. However, the installation of this joint is not essential. For a more reliable water tightness with time, we recommend that you only use sealing paste.

Caution : in order to guarantee the accuracy of the sensor, the sensor axis must be parallel to the lubber line of the ship. A dissymmetry of the speed measurement causes a significant error on the calculation of true wind.

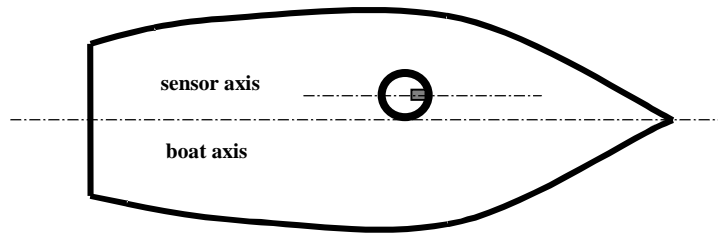
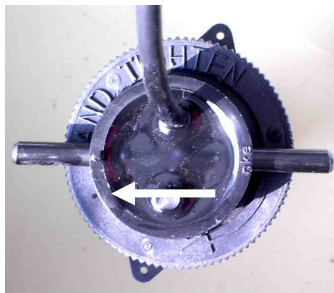

Figure 5

4.6 Installation of the **ULTRASONIC SPEEDO** sensor

- Grease the two O-rings of the sensor with the silicon lubricant.
- Introduce the sensor in the through-hull.
- Gently screw the sensor nut until you feel a slight resistance.
- Then rotate the body of the sensor to position the small arrow located on top of the sensor towards the bow of the ship, and the handle parallel to the centreline of the ship.



- Manually tighten the nut, to the thread root.

CAUTION :

- Do not introduce the sensor in the through-hull without lubrication, as it may damage the seals.

4.7 Installation of the safety wire

The metal safety wire allows to block the rotation of the sensor nut. Install the safety wire according to the instructions on figure 4.

4.8 Adapter for the old *nke* through-hull : 31-36-002

If your ship is already equipped with an *nke* through-hull (ref : 31-01-006), you can use the adapter reference **31-36-002** to install the **ULTRASONIC SPEEDO** sensor. This adapter allows you to install the sensor into the diameter of the old through-hull easily and with no tools.

4.9 Electrical connection to the *Topline Loch Sounder Interface*

The sensor is equipped with a 10 metre cable and a waterproof connector. You will connect the **ULTRASONIC SPEEDO** sensor onto the connector socket marked **speed sensor** of the **loch sounder interface** housing.

CAUTION :

- To guarantee the watertightness of the connectors, make sure they are properly screwed onto their connector socket.
- The connection of the sensor must be performed with the installation power switched off.

5 MAINTENANCE

5.1 Recommendations

- The sensor is coated with silicon grease. It is however **recommended to lubricate it regularly** (silicone grease only) in order to avoid locking in the through-hull.
- The immersed face of the sensor may become covered with algae and seashells. Periodically clean the immersed surface of the sensor. If you do not use your instruments for a long period of time, remove the sensor from the through-hull and place a stopper. We recommend that you protect the immersed face of the sensor with a thin layer of antifouling, to guarantee the performance of your sensor.

5.2 How to remove a sensor from the through-hull ?

To perform maintenance and cleaning operations, it is necessary to remove the sensor from the through-hull, when the ship is afloat. The sensor must be retrieved, then the hole of the through-hull must be rapidly blocked with the stopper. This operation may seem difficult, because water comes into the ship. However, with a bit of method and organisation, it can be performed easily. Only a few decilitres of water will come inside the ship.

Procedure :

1. Clear the area around the sensor.
2. Lubricate the stopper and keep it within your reach.
3. Unscrew the sensor nut entirely.
4. Progressively retrieve the sensor, and be ready to block the through-hull with the stopper.
5. As soon as the sensor is removed, block the hole of the through-hull with the stopper, and screw.
8. Only a few decilitres of water will come inside the ship.

Note :

- The through-hull of the sensor is fitted with a valve. The latter is not waterproof but will restrict water intake before the stopper is immediately put in place.

NOTES

NOTES
