

# PRODUCT MANUAL

**58ST FS** (V.2.0.F)

**62ST FS** (V.2.0.F)



## EXPLODED VIEW

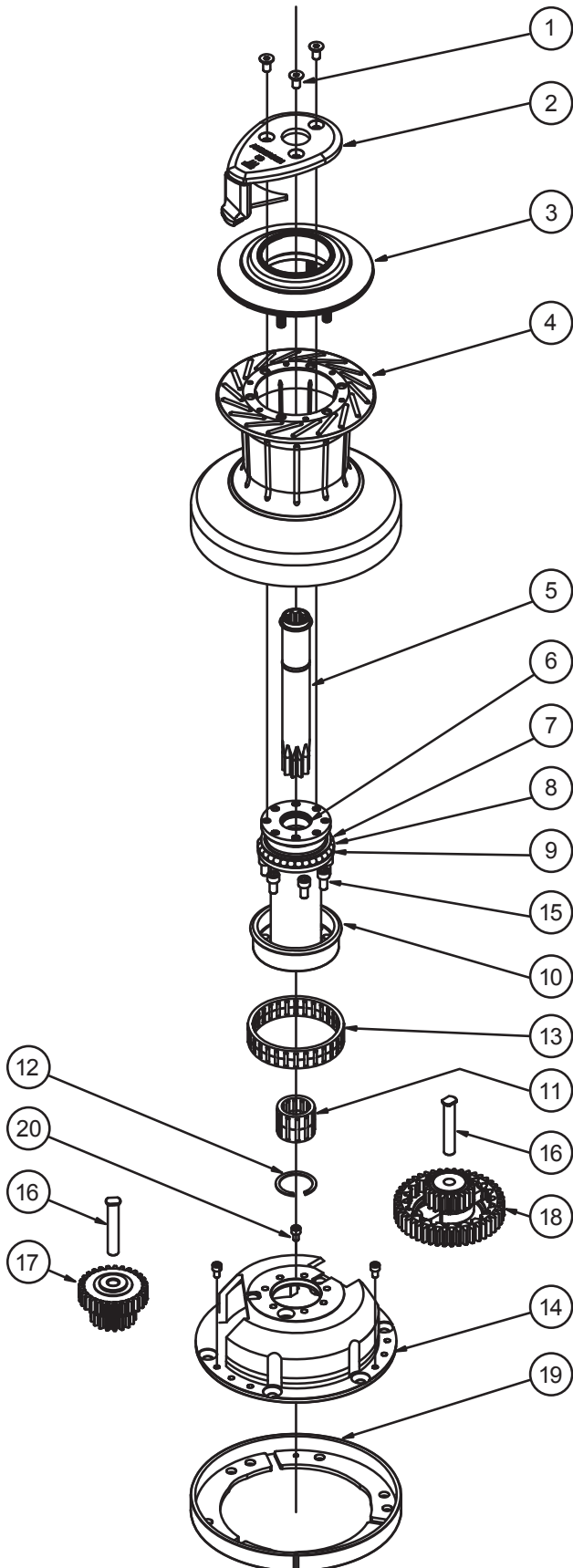

ITEM No. 3 - 736111

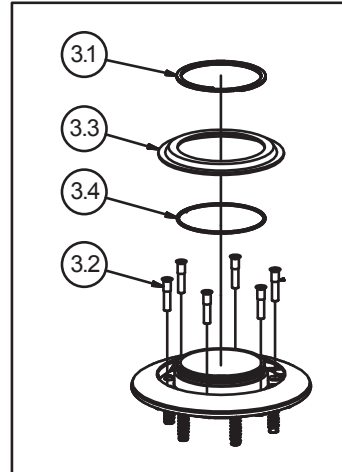

ITEM No. 17 - 775700

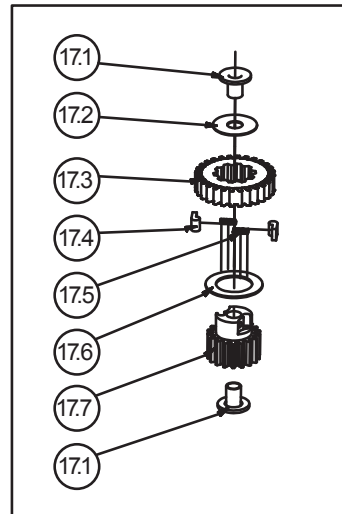

ITEM No. 18 - 774700

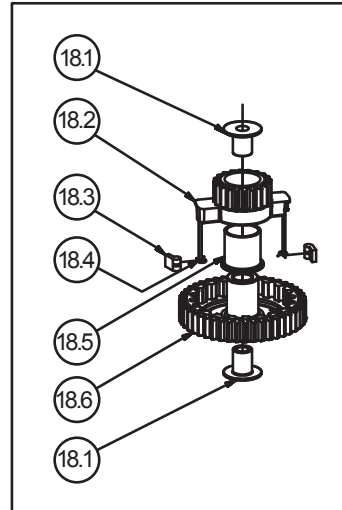

## I PARTS LIST

ITEM NO.	QTY.	DESCRIPTION	PART NO.
1	3	Screw	543312
2	1	Self-tailing arm - Model 58ST	544601
2	1	Self-tailing arm - Model 62ST	544610
3	1	Self-tailing top complete - Model ST FS	736111
3.1	1	Circlip	590400U
3.2	6	Screw	585140
3.3	1	Top ring - Model ST	521201
3.4	1	O-ring	RD100432
4	1	Drum complete	745302
5	1	Drive shaft complete	527800
6	1	Bushing (not removable)	716503
7	1	Retaining ring (not removable)	524500
8	14	Ball, stainless steel	526301
9	15	Ball, POM	536302
10	1	Upper base	745201
11	1	Roller bearing complete	724100
12	1	Circlip	724300
13	1	Roller bearing complete	528601
14	1	Lower base	745101
15	6	Screw	DIN912-A4-M8x16
16	2	Shaft	526800
17	1	Small ratchet gear complete - Model 58ST	775700
17	1	Small ratchet gear complete - Model 62ST	775750
17.1	2	Bushing	525600
17.2	1	Washer	524300
17.3	1	Ratchet gear wheel - Model 58ST	524900
17.3	1	Ratchet gear wheel - Model 62ST	529700
17.4	2	Pawl	533400
17.5	2	Spring	533500
17.6	1	Washer	526400
17.7	1	Gear wheel - Model 58ST	524800
17.7	1	Gear wheel - Model 62ST	520300
18	1	Pawl gear	774700
18.1	2	Bushing	786600
18.2	1	Pawl gear	774500
18.3	2	Pawl	713200
18.4	2	Arm spring	713300
18.5	1	Bushing	786500
18.6	1	Large ratchet gear	774600
19	1	Base cover - Model ST FS	745720
19	1	Base cover - Model ST FS (Electric models)	745721
20	3	Screw	DIN912-A4-M6x10
	1	Product manual	710258
	<b>1</b>	<b>Service kit 12 (not included)</b>	<b>710012</b>

## I MOUNTING INSTRUCTIONS

Installing the winch is easy, if you follow these instructions. The numbers in ( ) refer to the position numbers in the parts list.

### Tools required for the installation:

- Allen key (5 mm)
- Allen key (8 mm)
- Ø10.5 mm (13/32") drill
- Bedding compound
- 6 x M10 (3/8") countersunk head screws and corresponding nuts (length depending on deck thickness)
- 6 x large washers or backing plate
- Ring spanner to match nuts

1. Drill bolt holes Ø10,5mm (3/8") using the winch template.  
Be sure that no dust comes in contact with the winch, while drilling.
2. Remove screws (1).
3. Remove self-tailing arm (2) and drum (4).
4. Apply a light coat of bedding compound, ensuring that each bolt hole is bedded.  
Keep drain grooves clear.
5. Fasten lower base (14) into place using 6 pcs. M10 (3/8") countersunk head screws.  
Use large washers or a backing plate.
6. Assemble in reverse order.
7. Check that the winch is functioning correctly:
  - The drum should operate smoothly, when turning the drum clockwise by hand.
  - The drum must not turn when trying to turn the drum anti clockwise by hand.
  - While turning the winch handle clockwise the drum should turn slowly.
  - While turning the winch handle anti clockwise the drum should turn quickly.

## PAWL SPRING MOUNTING

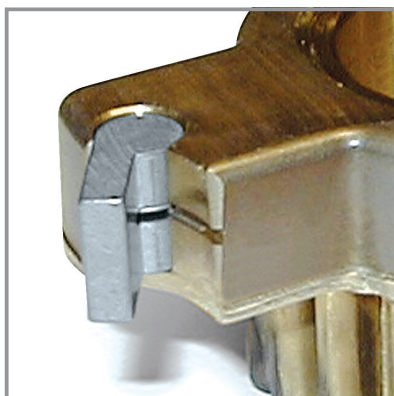

Note the curved  
spring "arm"

## SERVICE INSTRUCTIONS

### Tools required for service:

- Allen key (5 mm)
- Allen key (6 mm)
- Screwdriver (small)
- Winch handle
- ANDERSEN winch grease

1. Remove screws (1).
2. Remove self-tailing arm (2) and drum (4).
3. Remove drive shaft (5) .
4. Clean the balls (8, 9) with a rag.  
DO NOT remove the balls and the small retaining ring (7) above the balls.
5. Remove screws (15).
6. Remove upper base (10).
7. Remove roller bearing (13).
8. Remove shafts (16).
9. Remove and dismantle the two gear units (17), (18).
10. Clean all parts in white spirits/mineral spirits. Remember to clean the gear teeth and ball track inside the drum (4).
11. Assemble in reverse order. During assemble, by the use of a small soft brush lightly grease all gear teeth, drive shaft, roller bearing, shafts, pawls, springs and bushings. Pawls should only be lubricated with a very thin film of ANDERSEN WINCH GREASE. It is very important that pawls can move freely.

**IMPORTANT:** When assembling the winch, check the functioning of each pawl by pushing the pawl against the spring. The pawls should move smoothly and automatically return to their normal position, where the pawls engage with the teeth. If the pawls do not function correctly, clean and lubricate the pawls and gears. Check the function of the pawls again to make sure that it works correctly. If the pawls do not work correctly replace the springs and recheck the functioning.

Malfunctioning pawls may lead to unexpected release of the winch force resulting in fatal injuries to the user and others.

Service Kit No: 12 (part. no. 710012) contains spare parts for this winch.

### Maintenance instructions for PVD coated stainless steel surfaces.

PVD-coated surfaces should be rinsed regularly in fresh water to remove any salt residue, dirt or other contaminants and dried gently with a soft cloth. To remove grease or other marks, a mild abrasive free cleaning agent such as spray-on glass cleaning solution may be used. No caustic detergents or other aggressive or abrasive cleaning agents should ever be used, as they may damage the surface.

## GENERAL INFORMATION

Due to the best choice of materials and high precision in manufacturing, we recommend, for normal use, only to dismantle, clean and lubricate the winch once every second year. Under extensive use, such as racing, charter or blue water sailing, we recommend to lubricate the winch once every year.

We strongly recommend always to use ANDERSEN WINCH GREASE, when lubricating your winch. ANDERSEN WINCH GREASE is a high quality silicone/Teflon grease product.

Most other types of grease, including "marine grease" are not suitable for lubrication of winches. Non-suitable grease products can cause malfunction, which could result in fatal injuries for the user and others.

Pawl arm springs should be replaced every second year. Spare arm springs and other parts that may be required are included in the ANDERSEN Service Kit. Please refer to the service instruction for the Service Kit suitable for the specific winch.

When the winch handle is not in use but the winch is under load, we recommend, from a safety point of view, to remove the winch handle from the winch.

To ensure correct function of the self-tailing unit, only use recommended line sizes. When using the winch with mooring lines DO NOT use the self-tailing function and be sure that the mooring line is not in contact with the self-tailing arm.

To ensure the best possible functioning of the winch, we recommend that the winch is placed in accordance with the line entry (shown below).

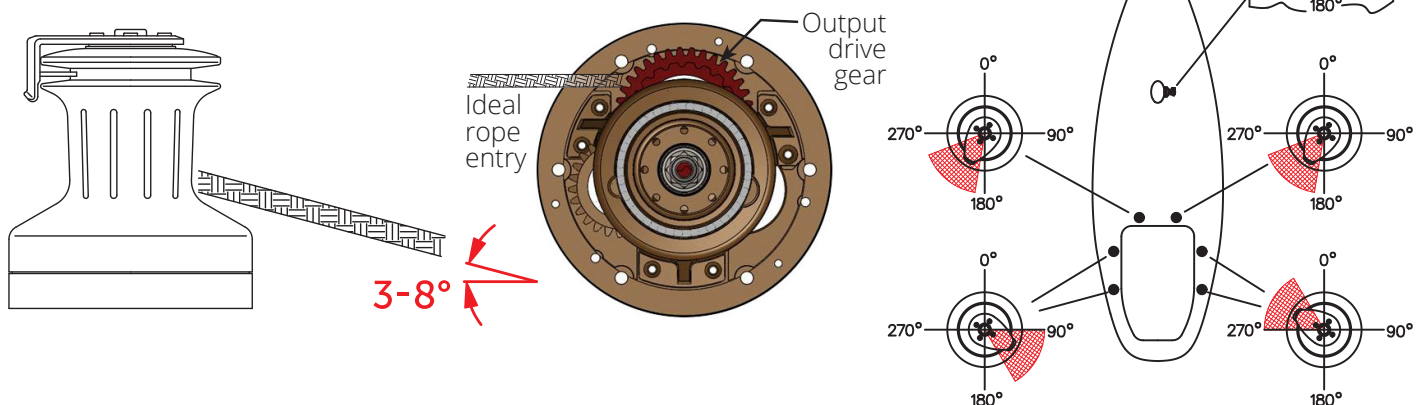

Be also aware that the self-tailing arm is positioned correctly. We recommend to have the self-tailing arm positioned within the shaded area (shown above). On this model the self-tailing arm can be placed in several different positions after having installed the winch.

To identify the Output Drive Gear, insert a winch handle into the winch and rotate in both directions, the drive gear will only rotate clockwise in a fast and slow speed.

## I SAFETY NOTICES

### I ALL WINCHES



#### **Read All Safety Notices and Product Manuals**

Do not install or operate this winch before reading and fully understanding the contents of this Product Manual.



#### **Stay Alert When Operating**

Andersen winches are very powerful and have the potential to cause significant damage and/or serious injury if used improperly or without due caution and vigilance.



#### **Operators Must be Trained**

Help prevent significant damage and/or serious injury by ensuring any person operating a winch has a thorough understanding of its proper operation and is aware of the potential hazards involved. As a minimum, all winch operators must read and understand this Safety Notice Sheet and the Product Manual.

Particular attention is drawn to the following points:

- Children and others not qualified to operate an electric winch must be kept at a safe distance from the winch and any rigging or fittings that are under load.
- Long hair and/or loose clothing must be tied back to avoid being caught in the winch.
- In the event of a rope override or other fault, stop the winch and turn off power before attempting to resolve the problem.



#### **Avoid Accidental Operation**

Remove winch handles and turn off power to the winch when not in use to help avoid unsupervised or unintentional operation. Failure to do so could result in significant damage and/or serious injury.



#### **Maintenance**

Turn off power to the winch before performing any maintenance or service tasks. Failure to do so could result in significant damage and/or serious injury.



#### **Lifting Operations**

The winch must not be operated with the rope in the self tailer when used in any kind of lifting operation.

Any lifting operations should be conducted by two persons in order to maintain constant visual contact with the object being lifted.

Furthermore the self tailer must not be used as a cleat for a rope used to lift or suspend any object. The rope must be secured properly by tying off, or leading to a suitable fitting such as a cleat or bollard.

**I Failure to observe these precautions could result in serious injury or death.**

**I DO NOT DISCARD**



# PRODUCT MANUAL

**58ST FS (V.2.0.F) | 62ST FS (V.2.0.F)**

p8

---

## **| WORLDWIDE DISTRIBUTION & SERVICE**

| Visit [www.andersenwinches.com](http://www.andersenwinches.com)

## **| WARRANTY**

| Visit [www.ronstan.com/warranty](http://www.ronstan.com/warranty)

**Manufactured by Ronstan Denmark ApS.**  
Jægervænget 36 - 7100 Vejle - Denmark  
office@ronstan.dk - [www.andersenwinches.com](http://www.andersenwinches.com)

