

Backstay Flicker

511-120-01 Backstay flicker small (for boats LOA <30 ft.)

511-121-01 Backstay flicker medium (for boats LOA 30-37 ft.)

511-123-01 Backstay flicker large (for boats LOA 37-43 ft.)

- General
- Included parts
- Assembly method

General

This product is designed for use on fractional rigs only. The Backstay flicker is fitted on top of the headbox, and used to pull the backstay clear of the sail when gibing and tacking. The Backstay flicker is NOT designed to carry the extra load from runners and checkstays - ONLY THE WEIGHT OF THE BACKSTAY.

The use of backstay flicker does not compensate for the need of accurate mast tuning in all conditions of sailing. See "Hints and Advice", page 43 (595-540).

Masthead equipment such as lights, antenna and wind indicators may have to be moved and refitted.

Make sure that the Backstay flicker has enough clearance to move freely under the instrument brackets etc, **when the Backstay flicker is bent into sailing position!**

Make sure that the Backstay doesn't touch the aft edge of the mast when it is in working position.

The clearance must be at least 5 mm between the instrument bracket, wind indicator fittings and other mast head equipment and the Backstay flicker.

Modification of the mast top equipment's may be necessary to secure the clearance.



The use of backstay flicker does not compensate for the need of accurate mast tuning in all conditions of sailing.

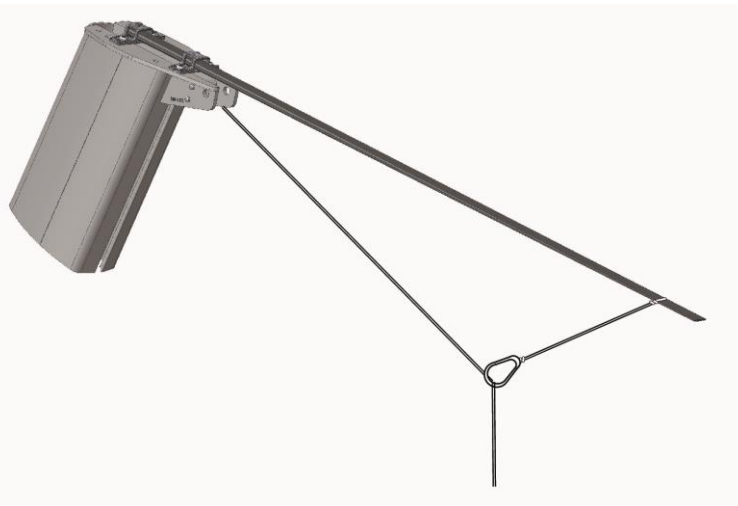

Parts included

	Qty
• 511-120-01/511-121-01/511-123 Backstay flicker	1
• 508-700 Bracket backstay flicker	2
• 155-701 M6 Self tapping Screws	4
• 162-026 M5 Screw	1
• 307-104 Thimble	1
• 592-006 Drillbit Ø 5.3 mm	1
• 613-052 Rope 0.8 m	1
• 595-993 Instructions for assembly	1

Assembly

1. Drill holes for the brackets. Use the enclosed $\text{Ø}5.3$ mm drillbit. The brackets should be placed at least 100 mm apart.
NOTE! Do not drill into the mast walls.
2. The brackets can be cut, to fit smaller headboxes, see fig. 3.
3. The brackets should be insulated from the aluminium headbox. Use sealant or a thick tape.
4. To insulate the selftapping stainless screws from the aluminum, apply water proof grease, Vaseline or anti-corrosive paste to the screws. Make sure that halyards and sheaves have enough space below the backstay flicker.
5. Fit the thimble to the backstay.
6. Slide the Backstay flicker into place.
7. Fit the locking screw in the hole at the end of the Backstay flicker.
Note: Do NOT drill any hole in the Backstay flicker at the aft bracket.
8. Fit the line in and around the Backstay flicker with running knots, (see fig. 6).
9. Fit the block with running knot around the thimble, (see fig. 5).
10. Adjust the length of the line to approximately 100 mm.

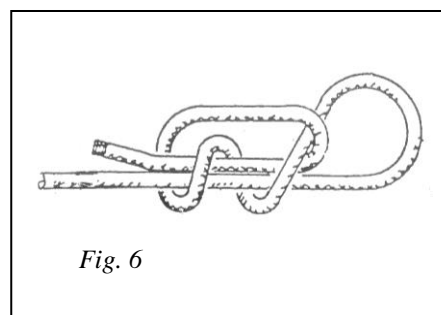
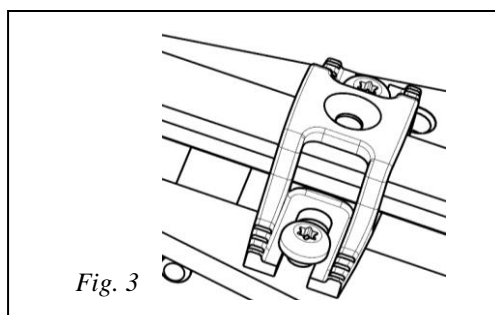
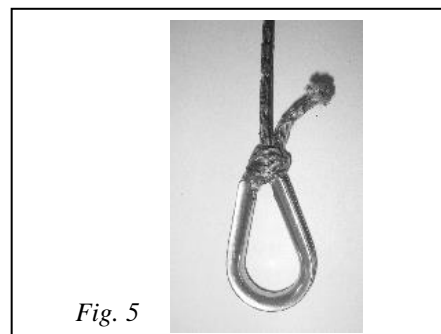
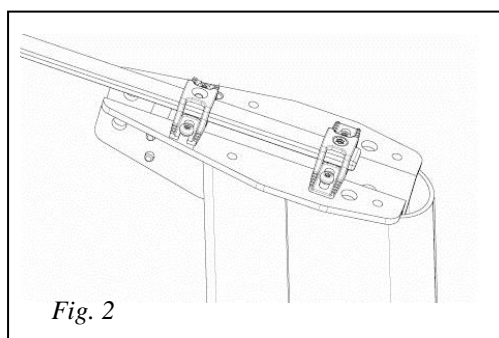
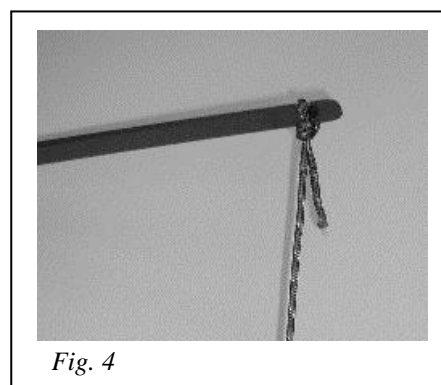
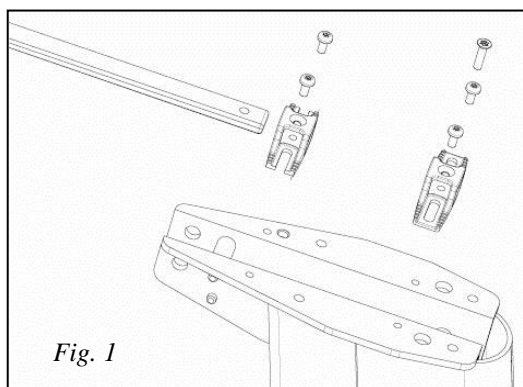

 **SELDÉN**

www.seldenmast.com