

Series 80 Gen 2 Continuous Line Furler

Product Manual



The furler you have purchased is designed for the furling of sails with a “straight” luff, such as code zero sails, screechers or staysails. These sails are generally for upwind sailing, at true wind angles less than 90°. The furler is designed to have the tack of the sail attached to the furler and the head of the sail attached to the top swivel. This will provide furling along the whole luff of the sail.

The sail must be either completely unfurled or furled – the furler cannot be used with a partially furled sail.

You will require a synthetic luff cable (torsion line) with a thimble at each end, connected between the fork of the furler at the bottom and the swivel at the top. We recommend you discuss options with your sail maker for torsion line type, diameter and length, to suit your requirements. Ronstan recommends FSE Robline GFL torsion line – contact us for more information.

Ronstan provides a range of accessories to suit this furler which can be found at the end of this manual.

FURLER SETUP:

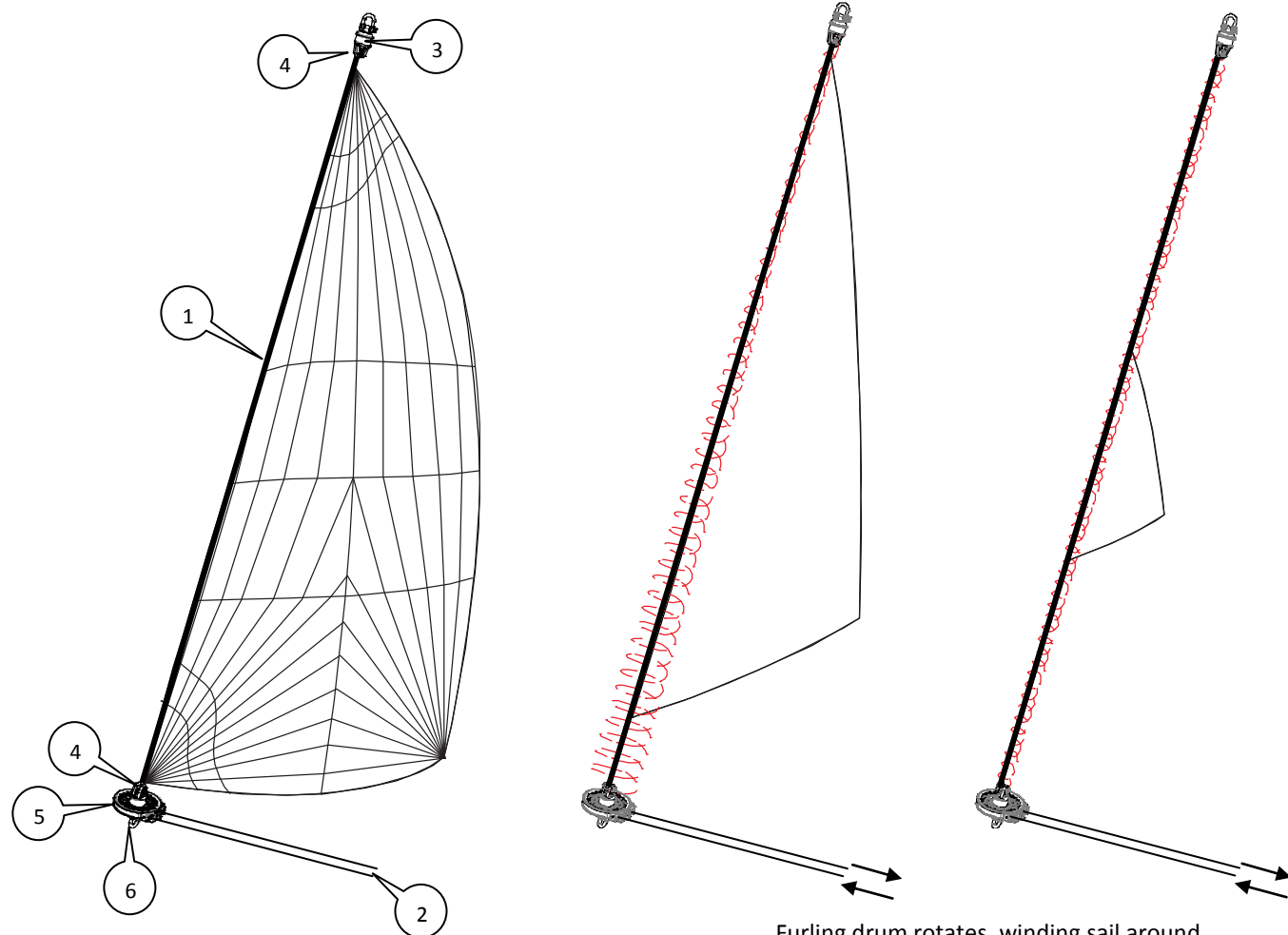

- 1. Torsion Cable
 - 2. Continuous Furling Line
 - 3. Top Swivel
 - 4. Thimble
 - 5. Furler
 - 6. Furler Attachment *
- (* Shackle, Snap Shackle or 2:1 fairlead – refer to “accessories” for more information.)

Furling drum rotates, winding sail around the luff cable along its full length.

CONTINUOUS FURLING LINE INSTALLATION & REMOVAL:

The Gen 2 range of Ronstan furlers feature easy furling line installation and removal. This allows easier furler attachment and removal if the furling line is permanently routed back to the cockpit through mounted blocks or fairleads.

Ronstan recommends FSE Robline Sirius 500 polyester braid, 8mm (5/16”) for the continuous furling line – contact us for more information.

1. Locate the slot cut in the bottom drum plate and turn the drum until the slot lines up with the opening in the guide.
2. Push the rope through the guide opening and deep in to the slot until the rope is in the hole.
3. Rotate the drum all the way around until the slot lines up with the guide opening on the other side of the guide.
4. Pull the rope out through the guide opening.

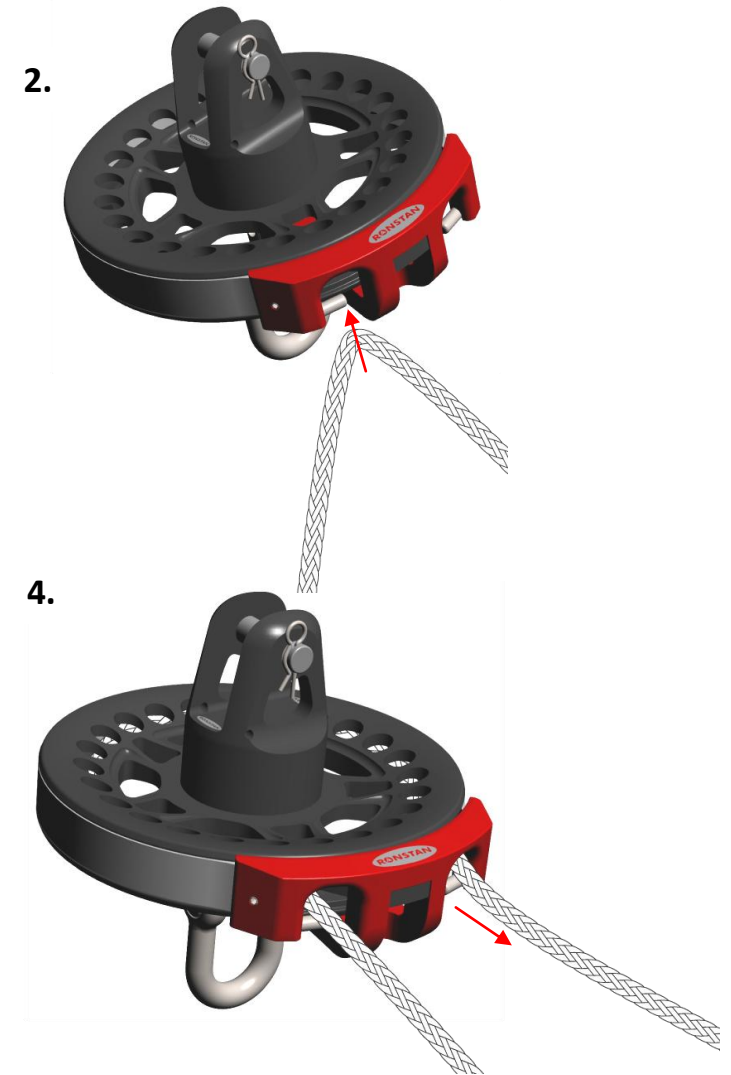
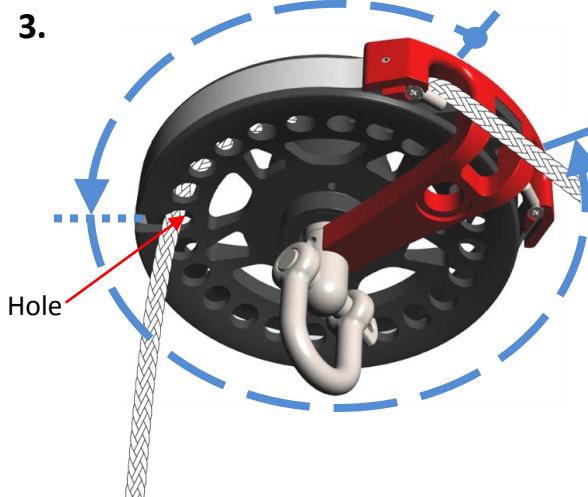
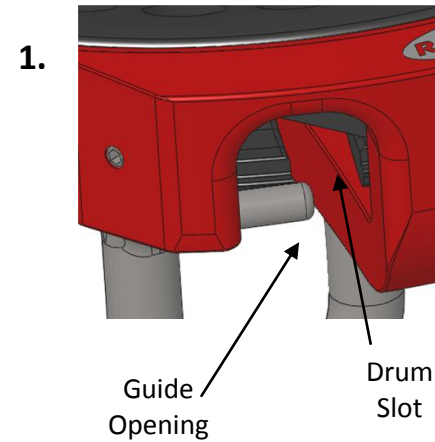

FURLING LINE ALIGNMENT:

It is important that the furling line is correctly aligned with the guide as shown below. Blocks or fairleads should be used to guide the line where required.

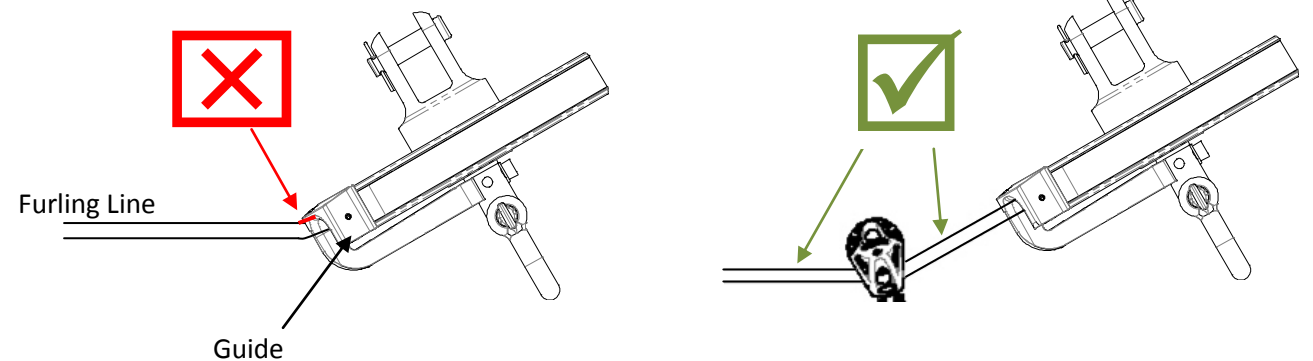

Two Cam cleats can be used to secure the furling line when not in use and keep the sail from unfurling.

GUIDE ARM ALIGNMENT:

The guide arm can be positioned in line or at 90 degrees to correctly align the furler mount with the deck or bowsprit attachment.

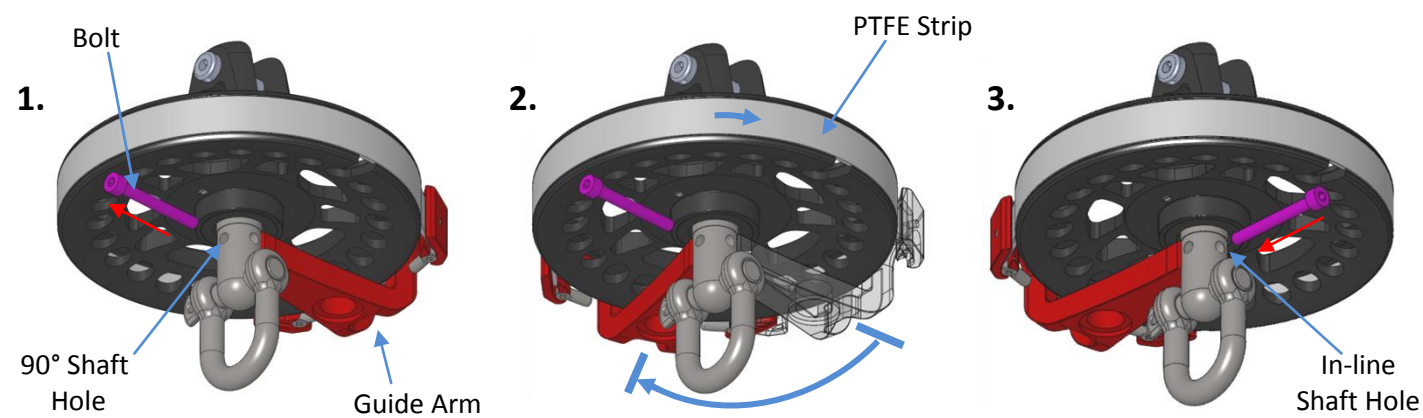

To change the orientation of the guide arm:

1. Remove the bolt located in the guide arm underneath the drum.
2. Rotate the guide arm and PTFE strip by 90° until the hole in the guide arm lines up with the alternate hole in the shaft.
3. Re-connect the guide arm to the shaft using the same bolt.

ACCESSORIES:

RS208020 - Snap-Shackle Adaptor

Simply replace the shackle on the furler or top swivel with the snap-shackle adaptor for quick attachment of the furler to your bow fitting or the top swivel to your halyard.

RS208030 - 2:1 Fairlead

Use in place of the shackle on the furler to provide a 2:1 purchase on the furler attachment. The tack line is dead ended at the deck or end of the bowsprit, runs up around the 2:1 fairlead, back down to a block, and back along the deck to a rope clutch. This configuration is a popular way of adjusting tension in the torsion cable, and hence the luff of the sail.



RS208040 – Thimble

Used to terminate the torsion cable at both ends by wrapping the torsion cable around the thimble and then either stitching it to itself, or splicing it. The thimble also has an additional hole suited to lashing the tack of the sail to it. Lashing the sail to the thimble and not to the furler allows the torsion line and sail to be easily removed from the furler and top swivel as required.

RS208050 – Shackle

Replacement shackles can be ordered to suit both the top swivel and the furler.

RS208080 – Top Swivel Lashing Pin

Use in place of the clevis pin on the top swivel to provide a more positive drive to the head of the sail. This helps to ensure a tight furl at the head. The head of the sail is lashed to the cotton reels on the ends of the pin while the torsion cable and thimble are attached to the centre section of the pin.



MAINTENANCE:

- Rinse regularly with fresh water to remove salt.
- Apply Ronstan RF3000 Sailfast (or a similar silicon based lubricant) over the body and components to enhance performance and prolong service life. (Do not use petro-chemical lubricants).
- Periodically remove fasteners and re-apply Tef-Gel® (TG-10) to prevent corrosion.
- Factory sealed bearings are maintenance free. Bearing and seal replacement can be arranged through your local Ronstan reseller.
- Furlers have a three year warranty – refer to www.ronstan.com for terms and conditions.

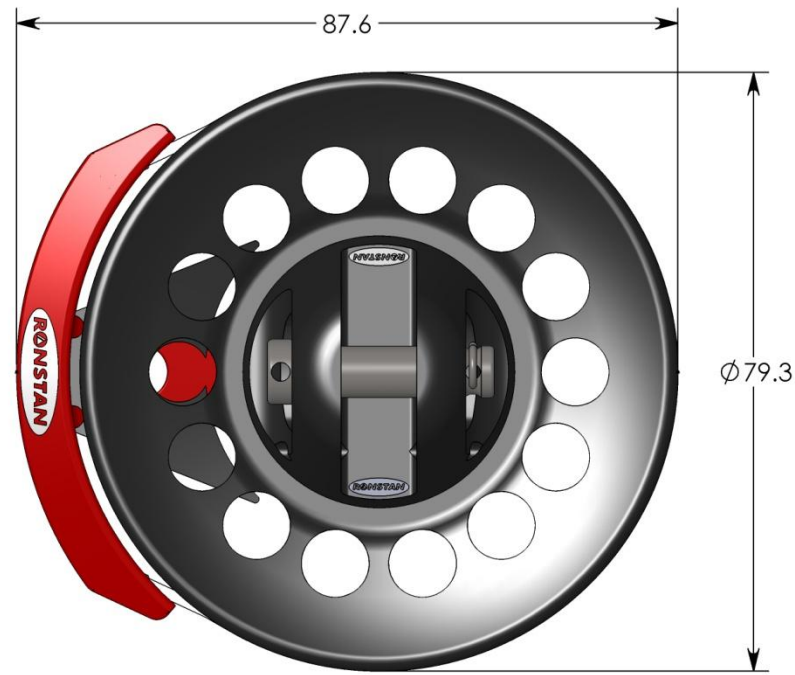

FURLER

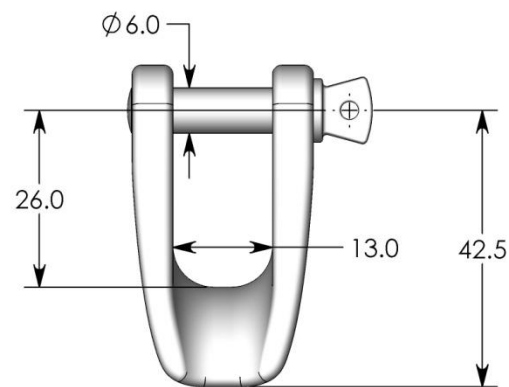
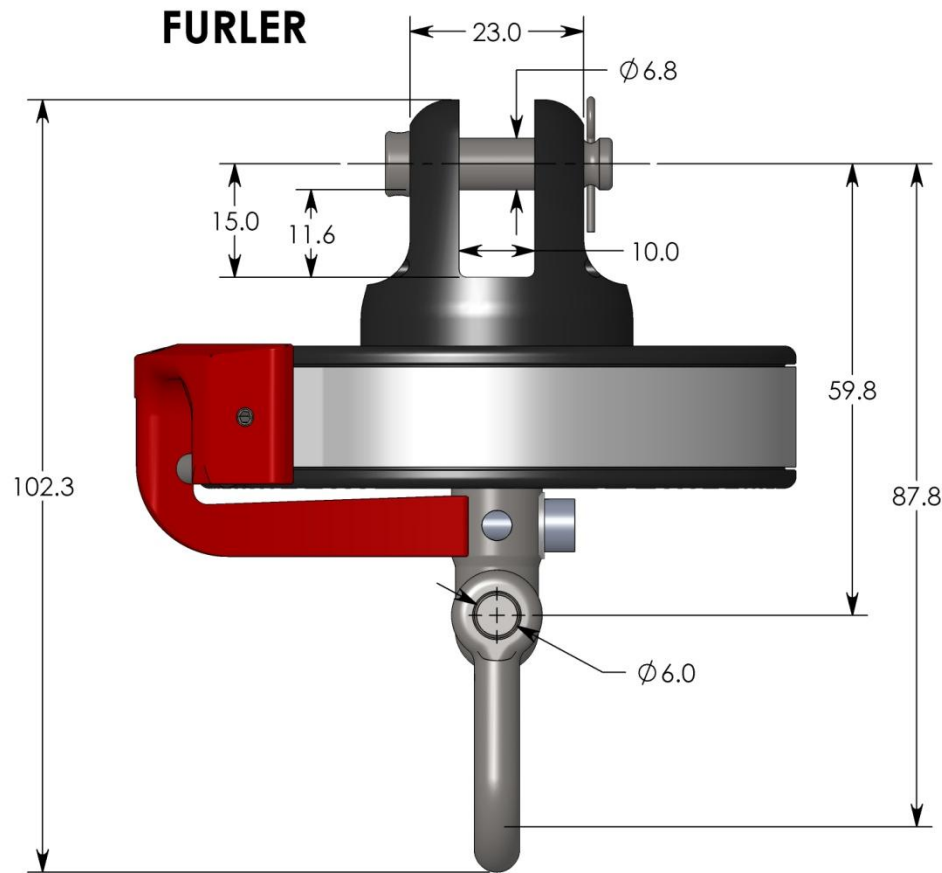

**2:1 FAIRLEAD
RS208030**



**TOP SWIVEL
RS208010**

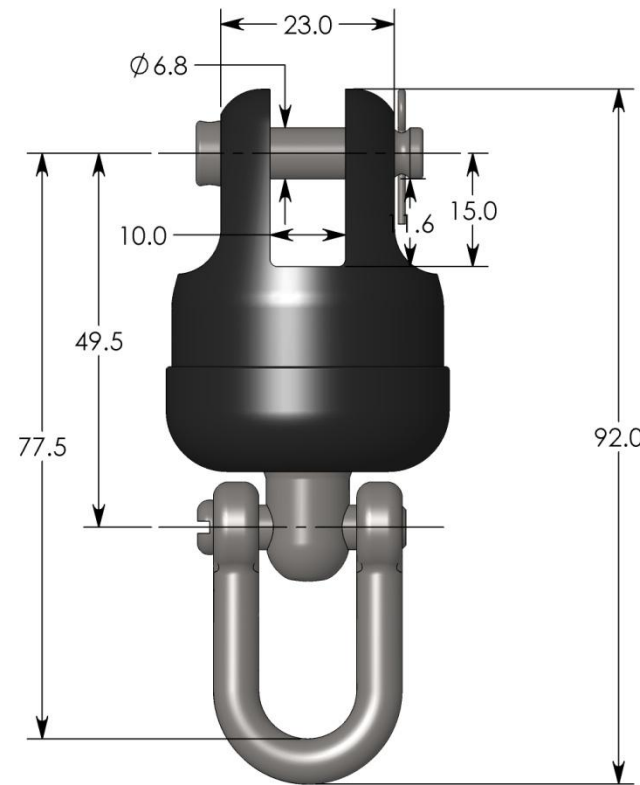

**SHACKLE
RS208050**

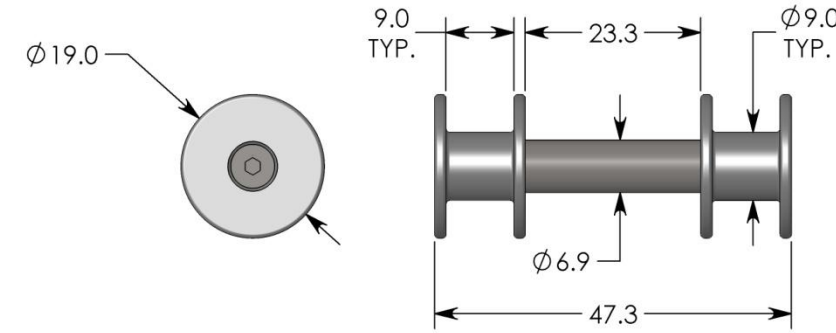
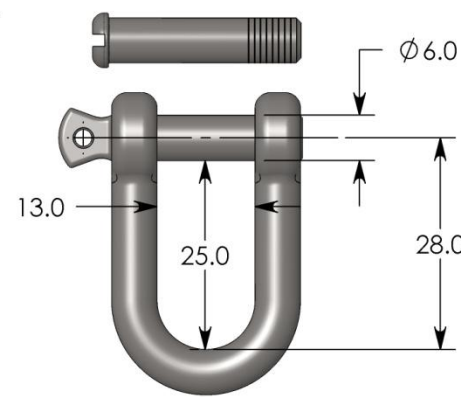

**TOP SWIVEL
LASHING PIN
RS208080**

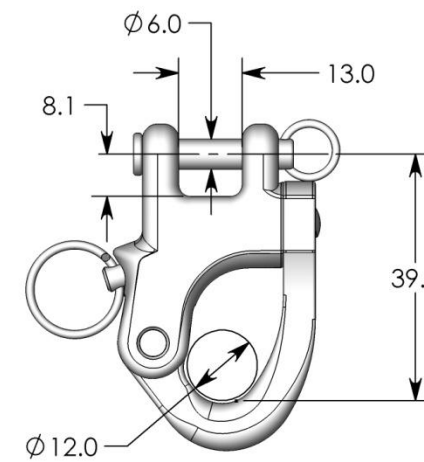

**SNAP-SHACKLE
ADAPTOR
RS208020**

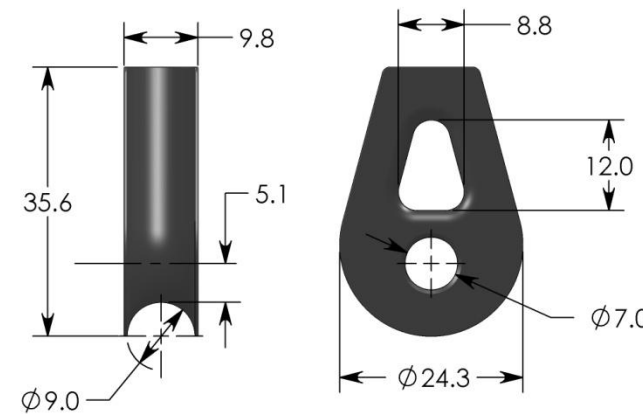

**THIMBLE
RS208040**

**SPECIFICATIONS: RS208700
S80 GEN 2 FURLER SET**

FURLER & SHACKLE
 MWL = 950kg (2090lb)
 BL = 1900kg (4190lb)
 WEIGHT * = 206g (7.3oz)
 FURLER LINE Ø = 8mm (5/16")
 SHACKLE = 6mm

RS212010 - TOP SWIVEL & SHACKLE WITH FLUSH PIN
 MWL = 950kg (2090lb)
 BL = 1900kg (4190lb)
 WEIGHT * = 111g (3.9oz)
 SHACKLE = 6mm

*Weight doesn't include Shackle

ACCESSORIES:

RS208020 - SNAP SHACKLE ADAPTOR
 MWL = 960kg (2120lb)
 BL = 2000kg (4410lb)
 WEIGHT = 54g (1.9oz)

RS208030 - 2:1 FAIRLEAD
 MWL = 1040kg (2290lb)
 BL = 2300kg (5070lb)
 WEIGHT = 44g (1.6oz)

RS208040 - LUFF LINE THIMBLE
 MATERIAL = AL6061, ANODISED
 WEIGHT = 8g (0.3oz)

RS208050 - SHACKLE, 6mm (PLUS FLUSH PIN)
 BL = 1950kg (4300lb)
 WEIGHT = 26g (0.9oz)

RS208080 - TOP SWIVEL LASHING PIN, 7mm
 MWL = 950kg (2090lb)
 BL = 1900kg (4190lb)
 WEIGHT = 29g (1.0oz)

THE DOCUMENT & THE DESIGN ON IT IS THE EXCLUSIVE PROPERTY OF RONSTAN INTERNATIONAL PTY. LTD. & IS THE SUBJECT OF COPYRIGHT.



DATE: 12/07/13
 ALL DIMS IN MM
 DO NOT SCALE

www.ronstan.com

TITLE: **Series 80 Gen 2 Furler Spec Sheet**