

PRELIMINARY

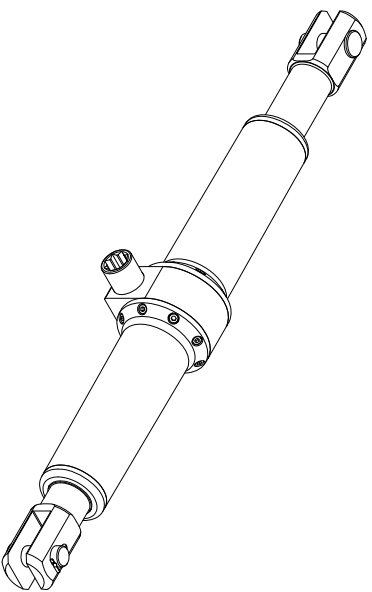
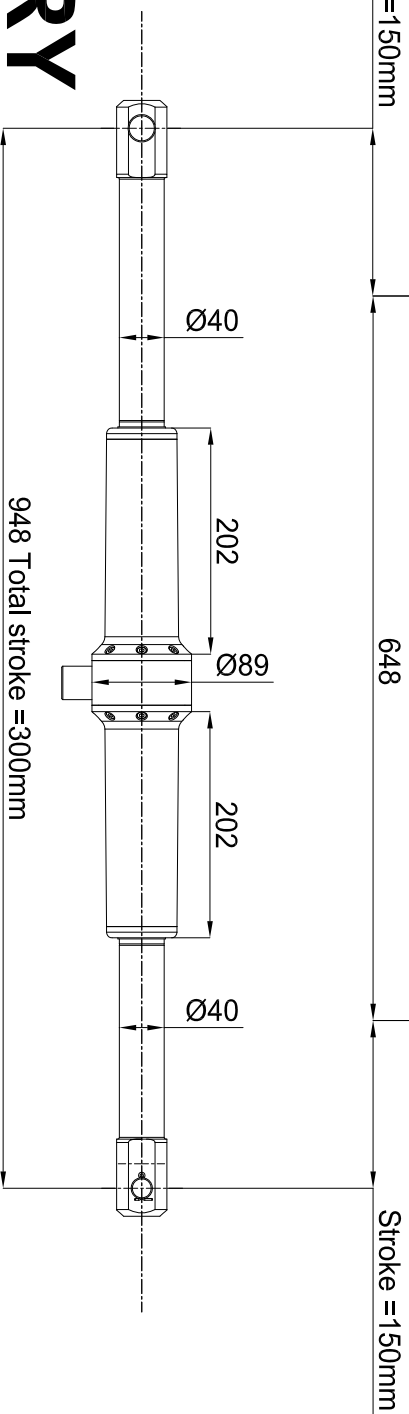

MATERIALS NOTE: ADJUSTER BODY BLACK HARDCOATE ANODIZED ALU - PINS & FORKS POLISHED S.S

REV.	DESCRIPTIONE MODIFICA - MODIFY DESCRIPTION	DATA - DATE	APPROVATO - APPROVED
A	FIRST ISSUE	11-03-2013	D.R.

Tolleranze dimensionali e geometriche per elementi in all. di tolleranza specifiche, secondo:
DIN - EN 1875 per tolleranze generali
UNI - EN 22768 m, K

Finiture prime di tolleranza da seguire:
Trasfondo: H9 - e7
Spigoli - Edges: 0.5 x 45°
Racordi - Fillets: R 0.5
Rugosità generali: Ra 3.2 / Rz 13

Descrizione - Description
LAYOUT BTM 12 STROKE 300mm

B disegno n° - Drawing n°
80107185
Codice

Macchina - Machine
REF.

Dimensioni - Dimensions
Dimensioni - Dimensions
Peso - Weight (Kg)
Q.tà - Qty

Zattini Group s.r.l. si riserva a termini di legge la proprietà di questo disegno, con divieto di riprodurlo o di renderlo comunque noto a terzi senza la specifica approvazione
Zattini Group srl holds the legal proprietary rights of this drawing. Unauthorized reproduction or disclosure of the drawing to third parties is forbidden

TECHNICAL DATA AND ILLUSTRATION ARE INDICATIVE AND NOT BINDING

TECHNICAL DATA	
MAX WORKING LOAD	7000 KG
WIRE	12
TOTAL STROKE	300 MM
CYLINDER WEIGHT	APPROX 7.45 KG

Zattini Group solutionsi meccaniche **banimar**

Scale - Scale: 1:1 Unit - Unit: mm

UNI A1