



ORBIT WINCH™

with QuickTrim™

PRODUCT MANUAL

RA6453 45QT ORBIT WINCH™, 3 SPEED

Winch Versions:

Version 0.0-1.0



45QT ORBIT WINCH™

INTRODUCTION

Your Ronstan Orbit Series winch is ready to provide you with many years of easy sail handling and reliable service.

Ronstan has been designing and manufacturing equipment for sailboats for more than 70 years. We are also known for our range of Andersen Stainless Steel Winches®, recognised around the world for their exceptional finish and enduring quality. The Orbit Series draws on the same engineering and manufacturing expertise to deliver a high-efficiency winch in lightweight aluminium. Controlled grip, smooth performance without excessive rope wear, and a patented QuickTrim™ feature on selected models that makes fine tuning a breeze.

You have some performance options to choose from, which need to be enabled before installing the winch, so please read this manual carefully from start to finish before proceeding.



RA6453 SPECIFICATIONS

Power ratio:	1st speed:	6.3:1
	2nd speed:	13.4:1
	3rd speed:	45.5:1
Rope dia.:	8-14mm	(5/16"-9/16")
Weight:	5.9 kg	(13.0 lb)
MWL:	1200 kg	(2650 lb)

BATCH NUMBER

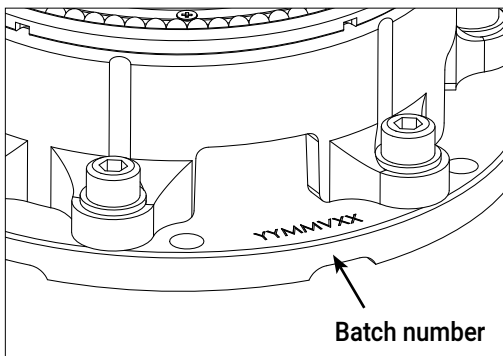

To assist with any future service inquiries, your winch has a batch number that is stamped onto the base of the centre stem in the location shown below. The self-tailing arm and drum need to be removed to access the batch number.

(Refer to steps 2 & 3 of the installation instructions).

SAFETY NOTICES

Read All Safety Notices and Product Manuals

Do not install or operate this winch before reading and fully understanding the contents of this Product Manual.

Stay Alert When Operating

Winches are very powerful and have the potential to cause significant damage and/or serious injury if used improperly or without due caution and vigilance.

Operators Must Be Trained

Help prevent significant damage and/or serious injury by ensuring any person operating a winch has a thorough understanding of its proper operation and is aware of the potential hazards involved. As a minimum, all winch operators must read and understand this Safety Notice Sheet and the Product Manual.

Particular attention is drawn to the following points:

- Children and others not qualified to operate a winch must be kept at a safe distance from the winch and any rigging or fittings that are under load.
- Long hair and/or loose clothing must be tied back to avoid being caught in the winch.
- In the event of a rope override or other fault with an electric winch, stop the winch and turn off power before attempting to resolve the problem.

Avoid Accidental Operation

Remove winch handles when not in use, and turn off power to electric winches to help avoid unsupervised or unintentional operation. Failure to do so could result in significant damage and/or serious injury.

Maintenance

Turn off power to an electric winch before performing any maintenance or service tasks. Failure to do so could result in significant damage and/or serious injury.

Lifting Operations

The winch must not be operated with the rope in the self tailer when used in any kind of lifting operation. Any lifting operations should be conducted by two persons in order to maintain constant visual contact with the object being lifted. Furthermore, the self tailer must not be used as a cleat for a rope used to lift or suspend any object. The rope must be secured properly by tying off or leading to a suitable fitting such as a cleat or bollard.

Failure to observe these precautions could result in serious injury or death.

EXPLODED VIEW

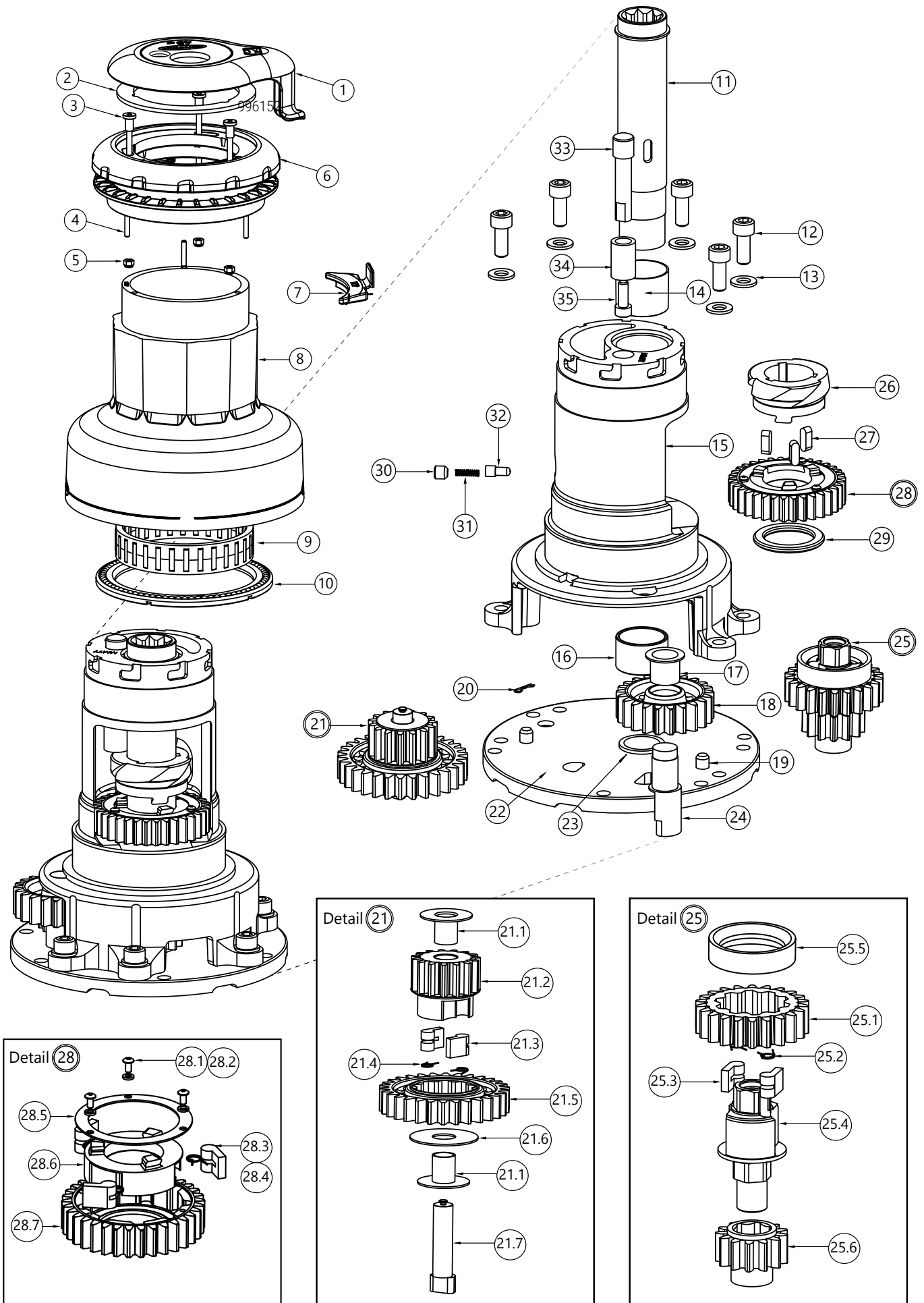

PARTS LIST

Item No.	Qty	Description	Part No.
1	1	Self-tailing arm assembly	996152
2	1	Closing washer	996065
3	3	Screw	996063
4	3	Locking pin	996015
5	3	Nut	NU4
6	1	Self tailer & QuickTrim™ assembly	996138
7	1	Rope splitter	996055
8	1	Drum	996070
9	1	Roller bearing assembly	996137
10	1	Ball bearing race assembly	996142
11	1	Shaft assembly	996232
12	5	Screw	SC5-820
13	5	Washer	DIN433-M8-WASHER
14	1	Shaft bearing	716501
15	1	Centre stem	996056
16	1	Bearing	996074
17	1	Top hat bearing insert	893200
18	1	Drive gear	996113
19	3	Dowel pin	996112
20	1	Retaining clip	92391A014
21	1	Ratchet gear assembly	996144
21.1	2	Bush	981410
21.2	1	Gear	996081
21.3	2	Pawls	713200
21.4	2	Pawl springs	713300
21.5	1	Ratchet gear	996082
21.6	1	Washer	524300
21.7	1	Gear axle	996080
22	1	Base plate	996077
23	1	Bearing	996073
24	1	Axle pin	996078
25	1	Central gear sub-assembly	996140
25.1	1	Ratchet gear	996114
25.2	2	Pawl springs	713300
25.3	2	Pawls	713200
25.4	1	Lower shaft	996186
25.5	1	Spacer	996265
25.6	1	Gear	996188
26	1	Top clutch	996089
27	3	Key	996112
28	1	Overdrive gear sub-assembly	996143
28.1	3	Screw	SC12-306
28.2	3	Washer	WSS-03
28.3	2	Pawls	713200
28.4	2	Pawl springs	713300
28.5	1	Retaining disc	996115
28.6	1	Clutch	996091
28.7	1	Ratchet gear	996092
29	1	Thrust washer	996098
30	2	Grub screw	GS88
31	2	Spring	996023
32	2	Plunger	996088
33	1	Overdrive button	996096
34	1	Overdrive plunger	996096
35	1	Screw	SC5-616

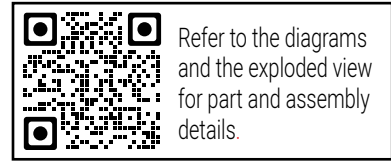

Refer to the diagrams and the exploded view for part and assembly details.

Winch Pawl & Spring Kit RA710052 contains 8 pawls and 16 springs.

INSTALLATION

Required for the installation:

- 6 x M8 or 5/16" Grade 316 stainless steel fasteners (length as required for deck thickness). Use of A4-70 DIN7991 hexagon socket cylinder head screws is recommended, installed at a torque setting of no more than 17.1Nm as per industry standards.
- 6 x Grade 316 stainless steel large washers or backing plate.
- 6 x Grade 316 stainless steel nuts to suit mounting fasteners.
- 6mm hex key
- Spanner, to suit mounting nuts.
- Drill bit, Ø8.5mm for M8 mounting bolts (or 11/32" holes for 5/16" bolts)
- Drilling template.
- Sealant / bedding compound.
- Tef-Gel™ isolating paste.
(Tef-Gel™ is a trademark of Ultra Safety Systems, Inc.)

Determine winch mounting position

Determine the mounting position for the winch and ensure that the mounting surface is smooth and flat.

The winch should be positioned with the recommended line entry angle of 3-8° from horizontal. Refer to the diagrams below:

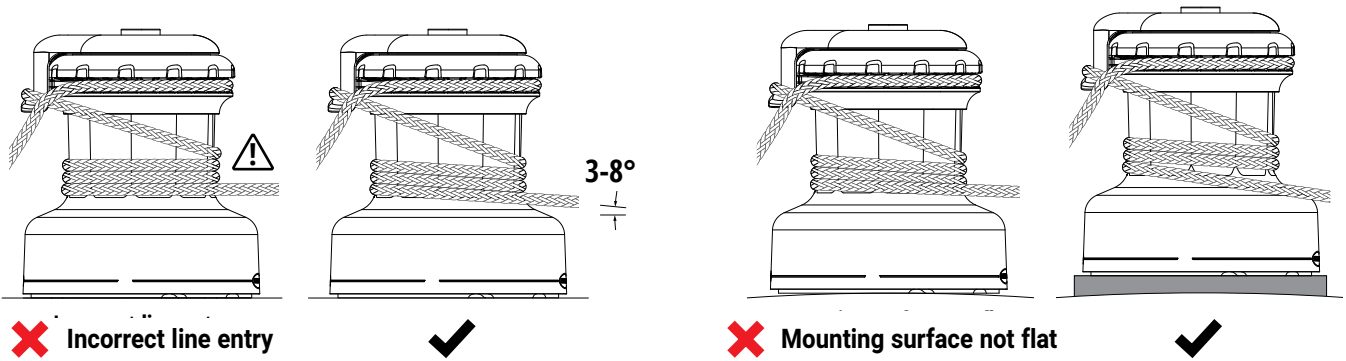

The drive gear should be aligned to the line entry as per the diagram and as indicated on the drilling template.

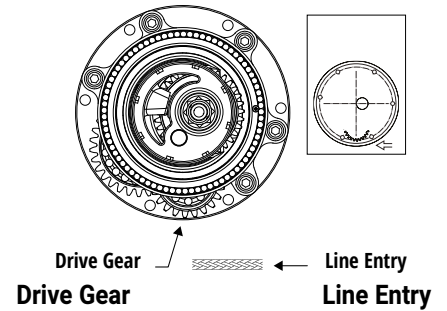

Step 1:

After confirming the mounting location and orientation of the winch, clean the mounting surface and tape the drilling template on the mounting surface so that it matches the required winch mounting position and orientation.

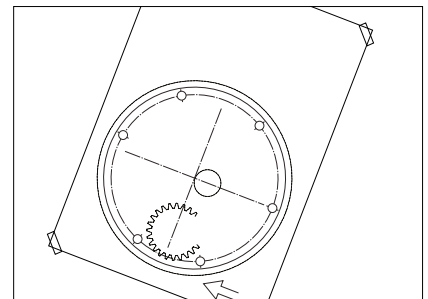

Step 2:

Remove the self-tailing arm [1]:

Pull back the spring-loaded release latch on the self-tailing arm [1] with a fingertip ①, then rotate the arm slightly in an anti-clockwise direction ② until it can be lifted clear of the winch ③.

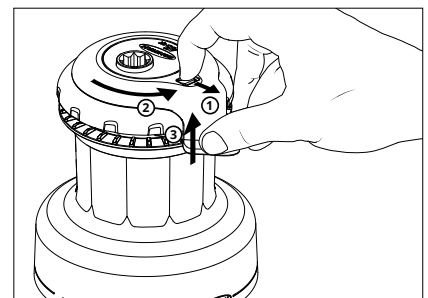

Step 3:

Remove the drum:

Grip the top of the drum assembly [8] with your fingers and pull vertically upward to remove it from the centre stem [15]. As the winch is not fixed to the deck yet, you may need to push gently with your thumbs against the central drive shaft [11] to separate the parts. Set the drum assembly [8] aside for now.

Place the centre stem [15] on the drilling template with mounting hole positions aligned to check that the orientation of line entry in relation to the output drive gear [18] is correct.

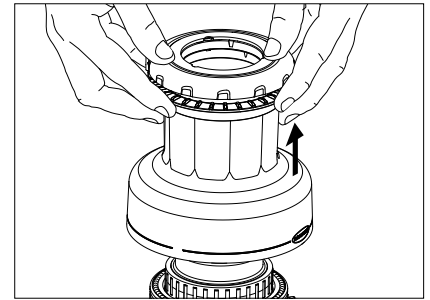

Step 4:

Drill the mounting holes:

With the template in place, drill the Ø8.5mm holes for the M8 mounting bolts (or Ø11/32" holes for 5/16" bolts).

Remove the template, clean away any debris from the holes, and clean the deck thoroughly to ensure deck sealant can adhere properly.

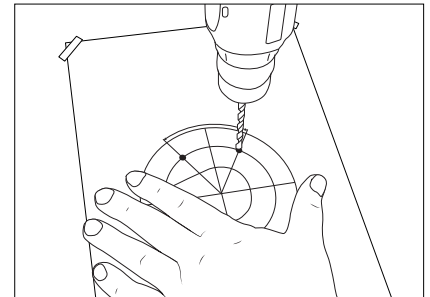

Step 5:

Apply sealant under the base plate [22] around the mounting holes, ensuring that the drainage channels in the underside of the base plate [22] remain clean and free of sealant. For mounting on metal or carbon fibre surfaces, the base plate [22] must also be completely isolated from the mounting surface to prevent galvanic corrosion.

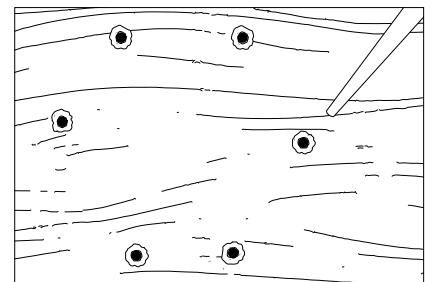

Step 6:

Fasten the winch to the deck:

Fit the base plate [22] to the deck using large washers (or backing plate) and nuts below deck. Apply Tef-Gel™ under the head of each mounting fastener to isolate them from the aluminium base plate [22].

To avoid wearing the anodised surface of the base plate [22] use a hex key to prevent the fastener from turning and use a spanner to tighten the nuts from below*.

* 6x M8 or 5/16" Grade 316 stainless steel fasteners. Use of grade A4-70 hexagon socket cylinder head screws is recommended, installed at a torque setting of no more than 17.1Nm as per industry standards.

Tef-Gel™ is a trademark of Ultra Safety Systems, Inc.

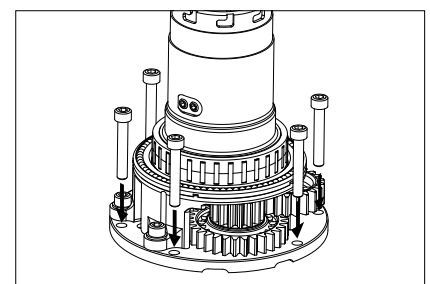

Step 7:

Re-assemble the winch drum:

Lift the drum assembly [8] over the centre stem [15], then slide it fully down into position.

Lay the closing washer [2] in its recess within the self tailer, taking care that the correct side is facing upward.

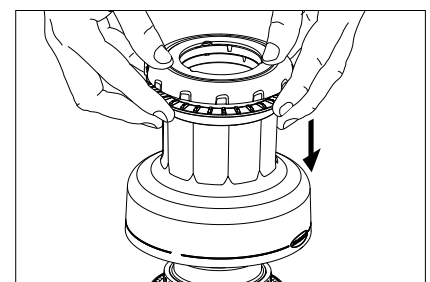

Step 8:

Self-Tailing Arm Orientation:

This image can be used as a guide to the orientation of the self-tailing arm [1] in typical locations on the deck. The self-tailing arm should be positioned to allow the rope to drop clear of the winch as it feeds out of the self tailer. Positions will typically be as indicated by the highlighted sectors in the diagram due to the clockwise rotation of the winch drum.

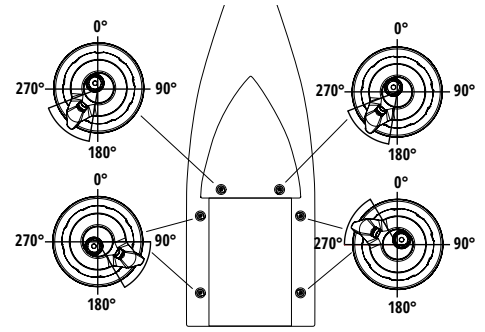

Fit the self-tailing arm:

Position the self-tailing arm [1] over the winch so that it overhangs the rope splitter [7]. Rotate the closing plate within the self tailing arm to align with the shaft. Rest the arm in this position so that it is centred.

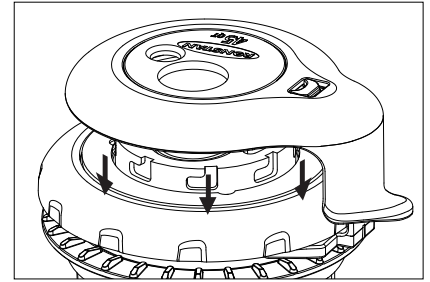

Rotate the self-tailing arm to its desired position, checking again to ensure that it overhangs the rope splitter [7]. Allow the part of the arm opposite the spring-loaded release latch to align with a bayonet notch in the centre stem and drop into engagement. Pull back the spring-loaded release latch on the self-tailing arm [1] with a fingertip ① and allow the arm to seat itself in the bayonet notches all the way around. Then rotate the arm slightly in a clockwise direction ③, and listen for the audible “click” indicating it is locked in position ②. A visible red flash indicates that the spring-loaded release latch is not fully engaged with the bayonet notches.

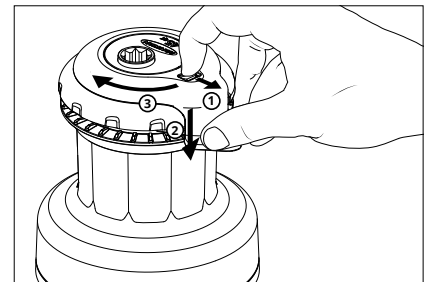

Step 9:

Before inserting a handle, check that the winch is functioning correctly:

Check that the drum turns smoothly when rotated by hand in a clockwise direction and is not able to turn in an anti-clockwise direction.

Insert a winch handle in the socket of the central drive shaft. Turning the handle in an clockwise direction should drive the drum in it's slowest speed; turning the handle in an anti-clockwise direction should drive it in the faster speed. For a three-speed winch, after pushing the button on top of the winch turning the handle clockwise should drive the winch in the fastest (overdrive) gear.

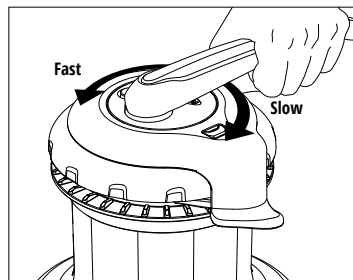

Overdrive button (not engaged).

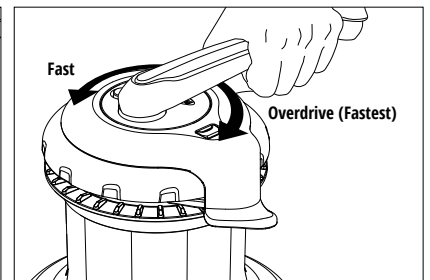

Overdrive button (engaged).

NOTE: Make sure that you familiarise yourself with the safety notices on page 3 of this manual before using the winch.

USING THREE-SPEED MODE

To engage the first gear with a fast 1.4:1 gear ratio (fast speed), push down the button on the top of the winch and turn the winch handle clockwise. When the load becomes too heavy, turn the handle anti-clockwise to switch to the second gear. The winch will now operate as a two-speed winch, shifting between second and third gear with changes in handle direction. To return to the first gear for fast speed, simply push the button again.

Note: Avoid activating fast speed when the winch is already under high load, as significant effort may be required in the second gear for disengagement. In this event, ease the rope to reduce the load to facilitate disengagement.

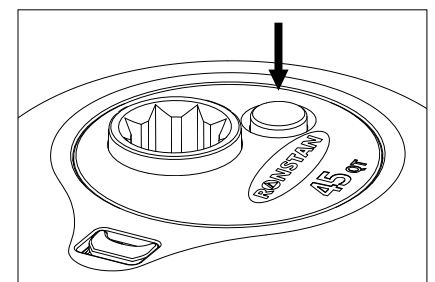

Using Three Speed.

QUICKTRIM™

About the QuickTrim™ feature.

QuickTrim™ is a patented innovation in self-tailing winches unique to Ronstan. It allows easing of line tension to make minor sail trim adjustments without the need to remove the line from the self tailer.

Your winch has been delivered from our factory so that it will operate only as a traditional self-tailing winch unless you enable the QuickTrim™ functionality by following these instructions. Once enabled, this feature should be demonstrated to new users so that they understand how to operate the winch correctly before use.

Optional enabling of QuickTrim™

Step 1:

Remove the self-tailing arm:

Pull back the spring-loaded release latch with a fingertip ① then rotate the self-tailing arm [1] slightly in a clockwise direction ② until it can be lifted clear of the winch ③. Then remove closing washer [3].

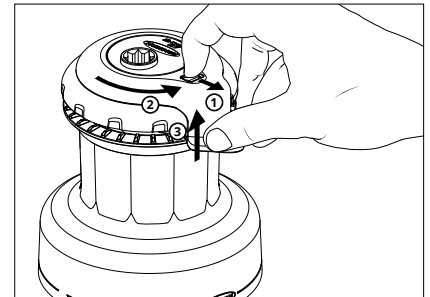

Step 2:

Locate and remove the countersunk cross-head screw as shown in the diagram (Keep the screw for future use if you wish to disable the QuickTrim™ feature again).

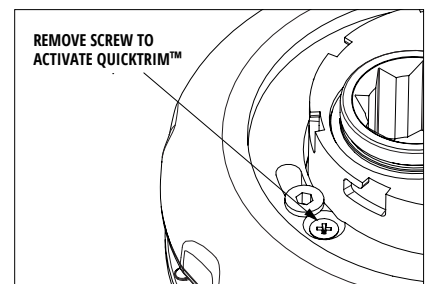

Step 3:

Replace the self-tailing arm [1] as described in Step 8 of the installation instructions.

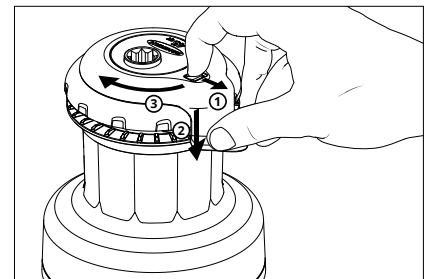

USING QUICKTRIM™

The winch operates in the same way as a traditional self-tailing winch for tensioning, easing and casting off the rope. With QuickTrim™ the user can easily and safely make minor adjustments to sail trim without having to remove the winch handle, and without having to take the rope out of the self tailer.

- To release line tension, first hold the tail of the rope in one hand. Place your other hand on the top cover of the self tailer, with your fingers lying across the rope.
- Use the palm of the hand to grip and rotate the top cover anti-clockwise against the spring pressure and maintain it in that position. The self tailer is now able to turn beneath the cover, allowing the line to be eased off the drum in a controlled manner.
- (As always, the grip of the winch depends on the load and the number of wraps on the drum; you can assist the movement of the rope on the drum while easing if desired, or try using fewer wraps on the drum).
- When the correct sail trim is achieved, simply allow the top cover to spring back to its original position. The self tailer is now locked, and the winch is ready for normal use.

QuickTrim™ is designed for minor adjustments and will be particularly useful in situations where frequent adjustment of tension is required in sheet, halyard and other applications.

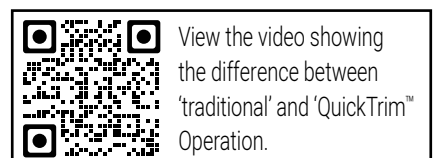
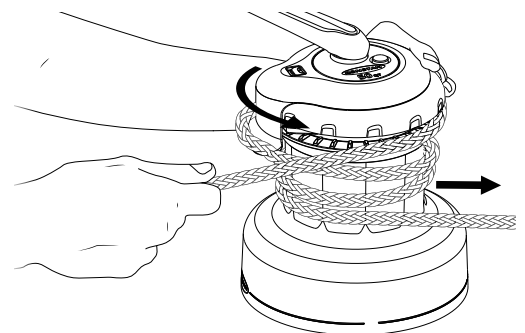

SERVICE & MAINTENANCE

General Maintenance:

As with all deck equipment, fresh water rinsing after each use is recommended to avoid accumulation of salt and other surface contaminants. We recommend a complete servicing of your winch (dismantle, clean and lubricate) every two years. Under extensive use such as racing, charter or extensive offshore sailing, complete servicing should be carried out on an annual basis.

We strongly recommend the use of ANDERSEN WINCH GREASE when lubricating your winch. ANDERSEN WINCH GREASE is a high-quality grease; most other types of grease, including some labelled "marine grease", are not suitable and may lead to malfunction which could result in serious injury to the user and others.

Pawls should be inspected, and springs should be replaced every second year. It is important to use only genuine Ronstan or Andersen brand pawls and springs in your winch.

Winch Pawl & Spring Kit RA710052 contains 8 pawls and 16 springs.

Required for service:

- Winch handle
- Hex key, 2mm for M3 fasteners, or 1/16" for 1/8" fasteners.
- Hex key, 6mm for M8 fasteners, or 1/4" for 5/16" fasteners.
- Small flat screwdriver
- White mineral spirits
- ANDERSEN winch grease and small brush for application
- Thread lock adhesive, medium strength

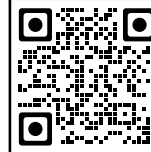

View the video showing
How to Service the winch

Winch Servicing Instructions:

Refer to the exploded view and parts list at the beginning of this manual for assembly details.

Proceed with the steps below to disassemble the winch, removing old grease and contaminants with white mineral spirits and inspecting all parts for wear or damage.

1. Remove self-tailing arm [1] and drum [8] as described in Installation Step 2&3.
2. Check that the spring-loaded release latch of the self-tailing arm is operating correctly and rinse thoroughly in fresh water. Inspect the self tailer assembly [6]. If QuickTrim™ is enabled, check that the self tailer cover rotates against the spring pressure to allow the self tailer to turn in an anti-clockwise direction, and springs back as expected to lock the self tailer and prevent it from turning independently of the drum. Rinse the self tailer mechanism thoroughly in fresh water.
3. Place winch handle into the shaft assembly [11] and lift upwards to expose the stainless steel keys [27]. Use a pair of pliers to remove the three keys [27] turning the winch handle and shaft to access them.
4. Lift out and remove the drive shaft [11].
5. Remove the top clutch [26], the overdrive gear [28] and the thrust washer [29].



6. Using the 6mm hex key remove both grub screws [30], springs [31] and plungers [32]. Inspect and clean parts. Lightly grease the plungers [32] before reassembling. Use a medium strength thread lock on the grub screws [30] when reassembling. It's important to ensure the grub screws [30] are tightened and flush with the centre stem [15].
7. Using a 2mm hex drive remove the three screws [28.1] and washers [28.2] from the overdrive gear [28]. Then remove the stainless steel retaining disc [28.5].
8. Disassemble the clutch [28.6] from the overdrive gear [28.7].



9. Remove the pawls [28.3] and pawl springs [28.4] from the clutch.
10. Clean all gears, pawls and pawl springs with a brush and white mineral spirits removing old grease and contaminants.
11. Apply a very thin film of Andersen Winch Grease to the pawls. Do not use any other kind of grease for this purpose.
12. Re-assemble the pawls [28.3] and pawl springs [28.4] into the clutch [28.6] taking care to assemble the springs in the correct orientation as shown below. Re-assemble the clutch into the overdrive gear.

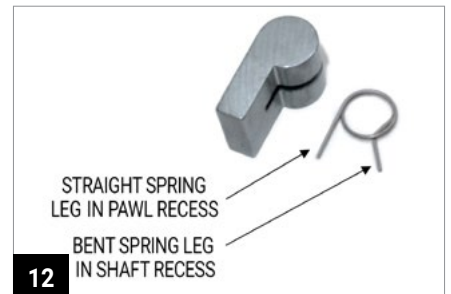
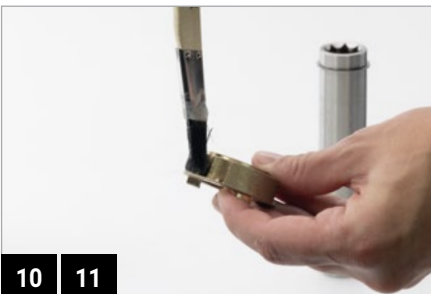

Malfunctioning pawls may lead to unexpected release of the winch force resulting in serious injury to the user and others. Check the functioning of each pawl by depressing against the spring. The pawls should move smoothly, and automatically return to their normal position to engage within the gears. If the pawls do not work correctly replace the springs and check again.

13. Place the thrust washer [29] in the groove on the underside of the re-assembled overdrive gear [28].
14. Place the thrust washer [29] and overdrive gear [28] into the bottom of the cut-out of the centre stem [15].
15. Insert the top clutch [26] into the side cut-out of the centre stem [15]. Ensure the upper surface of the top clutch [26] is in contact of the bottom of the overdrive plunger [34]. This can be checked by lifting the top clutch upwards; the overdrive button [33] on top of the winch should protrude as shown.

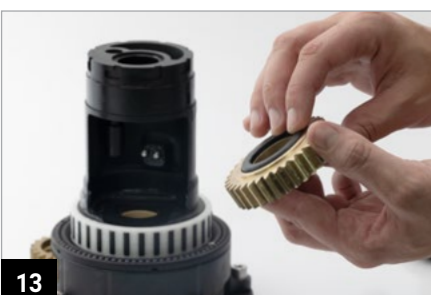

16. Hold the top clutch [26] approximately 10mm from the top of the overdrive gear [28].
17. While holding the top clutch [26] in this raised position, drop the drive shaft [11] in from the top of the centre stem [15].
18. Insert the three stainless steel keys [27] into the shaft assembly [11].
A small amount of grease on the keys will assist in keeping them in position as you rotate the shaft and insert all three keys.



19. Rotate the shaft [11] slowly until the keys [27] line up and engage with the grooves in the top clutch [26]. Continue to rotate the drive shaft [11] until it drops down to its home position.
20. Apply a very thin film of Andersen Winch Grease to the overdrive gear and clutch components.



Home position

21. Remove the ball bearing race [10] and the roller bearing [9] from the centre stem [15].
22. Remove the 5 screws [12] and washers [13] at the base of the centre stem [15] using a 6mm hex key.
23. Using a small flat screwdriver or pliers remove the retaining clip [20] to release the ratchet gear assembly [21].
Note: If removing the winch from the base plate leaving the retaining clip [20] in place will allow the centre stem and all gears to come away as one unit. This is useful if winch is being serviced off the boat.



24. Lift the centre stem [15] including the drive shaft [11] from the base plate [22] to expose the gears.
25. Remove the central gear assembly [25] and set aside.
26. Remove the drive gear [18] and axle pin [24] and set aside.



27. Remove the ratchet gear assembly [21] and set aside.
28. Disassemble the ratchet gear [21] by removing the gear axle [21.7], bushing [21.1] and washer [21.6]. Then separate the gear [21.2] from the ratchet gear [21.5].
29. Remove the two pawls [21.3] and pawl springs [21.4].
 Keep parts from each gear assembly separate for ease of re-assembly.



30. Remove the spacer [25.5] from the ratchet gear assembly.
31. Disassemble the ratchet gear [25.1]. Remove the gear [25.6] from the lower shaft [25.4].
32. Use a small flat screwdriver or knife to prise and release the two pawls [25.3] and pawl springs [25.2] from their recesses in the lower shaft [25.4].



33. Clean all gears, pawls and pawl springs with a brush and white mineral spirits to remove old grease and contaminants. Reassemble gear assemblies.
34. Apply a very thin film of Andersen Winch Grease to the pawls. Do not use any other kind of grease for this purpose. Take care to assemble with springs in the correct orientation as shown below. Replace the gear [25.6] and place the spacer over the top of the lower shaft [25.4] so that it rests on top of the gear [25.6].

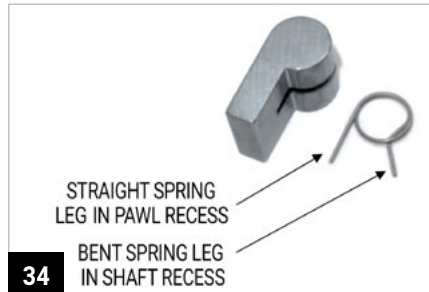

! Malfunctioning pawls may lead to unexpected release of the winch force resulting in serious injury to the user and others. Check the functioning of each pawl by depressing against the spring. The pawls should move smoothly, and automatically return to their normal position to engage within the gears. If the pawls do not work correctly replace the springs and check again.

35. Remove the three stainless steel dowel pins [19] and grease lightly, most before replacing.
36. Re-assemble the winch in reverse order.
37. During assembly, use a small soft brush to lightly grease all gear teeth, drive shaft and axles.
38. Replace the centre stem [15] and secure the retaining clip [20] to the top of the axle pin [18] of the drive gear [24].
39. Using a 6mm hex key fasten the centre stem [15] to the base plate [22] by replacing the 5 washers [13] and screws [12]. Tighten to torque setting of no more than 17.1Nm as per industry standard.

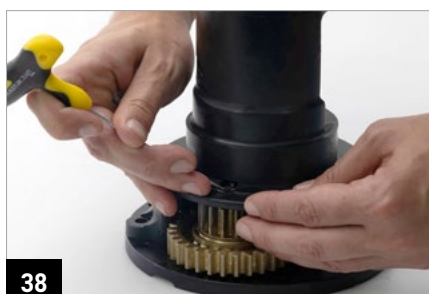

- 40. Replace the roller bearing assembly [9] and ball bearing race [10]. Both are self-lubricating and must not be greased.
- 41. Replace the drum and self tailing arm as per steps 7 and 8 from the installation instructions.



- 42. Check that the winch is functioning correctly as per step 9 from the installation instructions.
- 43. Check that the three-speed mode functions correctly as described on page 8 from the installation instructions.



User Instructions

ORBIT WINCH™ MOUNTING TEMPLATE



45QT & 50QT Mounting Dimensions Template

Winch Model	RA6452, RA6453, RA6502, RA6503
Scale	1:1
Page size	A4
Fasteners	5 x M8 or 5/16" stainless steel hex socket cylinder head screws, Grade A4-70

IMPORTANT This template document has been created at 1:1 scale. It is critical that it is printed at 1:1 scale. Check any printed/reproduced copies match the dimensions indicated at 1:1 scale prior to use.

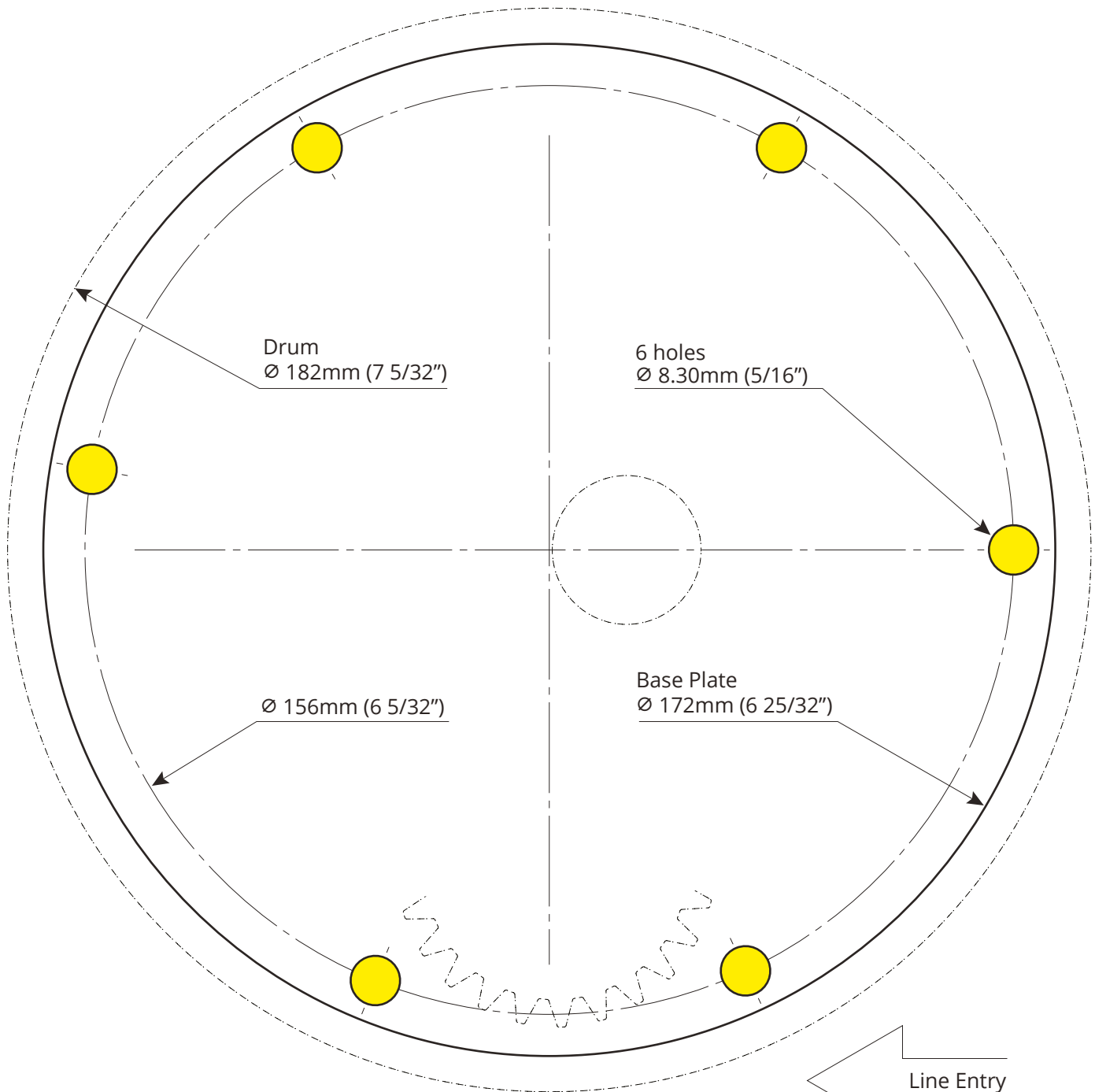

WORLDWIDE DISTRIBUTION & SUPPORT

www.ronstan.com

WARRANTY

www.ronstan.com/warranty

office@ronstan.dk

www.ronstan.com